

Transmission Technology Ses

SDH

CONTENTS

- SDH
- PROTECTION
- PLANNING
- SYNCHRONISATION

SDH: DISCUSSION AREA

**WHAT IS SDH ?
EVOLUTION
DRIVING FORCES
LIMITATIONS OF PDH
ADVANTAGES OF SDH
SIGNAL HIERARCHY
MULTIPLEXING STRUCTURE
FRAME REPRESENTATION
NETWORK ELEMENTS
NETWORK TOPOLOGY, etc....**

WHAT IS **S D H** ?

SYNCHRONOUS :
ONE MASTER CLOCK & ALL ELEMENTS
SYNCHRONISE WITH IT.

DIGITAL:
INFORMATION IN BINARY.

HIERARCHY:
SET OF BIT RATES IN A HIERARCHIAL
ORDER.

WHAT IS **SDH** ? (CONTD)

SDH IS AN ITU-T STANDARD FOR A HIGH CAPACITY TELECOM NETWORK.

SDH IS A SYNCHRONOUS DIGITAL TRANSPORT SYSTEM, AIM TO PROVIDE A SIMPLE, ECONOMICAL AND FLEXIBLE TELECOM INFRASTRUCTURE.

SYNC STANDARDS -EVOLUTION

ATTEMPTS TO FORMULATE STANDARDS FOR TRANSMISSION OF SYNCHRONOUS SIGNALS BEGAN IN U.S. AT THE BEGINNING OF 1984, BY ANSI ACCREDITED T1X1 COMMITTEE.

IN 1985 'SONET' STANDARD WAS BORN.

IN 1986 CCITT BECAME INTERESTED IN SONET STANDARD.

SYNC STANDARDS -EVOLUTION

(CONTD)

**CCITT PROPOSED CHANGES TO 'T1X1'
COMMITTEE TO ACCOMMODATE BOTH
AMERICAN AND EUROPEAN HIERARCHIES.**

**FINAL AGREEMENT WAS REACHED IN 1988
AND CCITT WORKING GROUP-XVIII CAME
OUT WITH RECOMMENDATIONS ON SDH.**

DRIVING FORCES

NEW ENHANCED SERVICES NEEDING SYNCHRONIZATION SOLUTION.

QoS REQUIREMENT

MULTI-OPERATOR ENVIRONMENT

LIMITATION OF TO-DAY'S NETWORK

ADVANTAGES OF SDH

LIMITATIONS OF PDH

- **NON STANDARD EXPERIENCES:**

- THREE DIFFERENT HIERARCHIES WITH DIFFERENT SIGNAL FORMATS AND LINE ENCODING METHODS.**

- **BASIS OF TODAY'S HIGH CAPACITY NETWORK**

- ELABORATE ARRANGEMENT FOR DROPPING**

- **NETWORK REQUIREMENT**

- CHANGING REQUIREMENT**

PDH HIERARCHIES

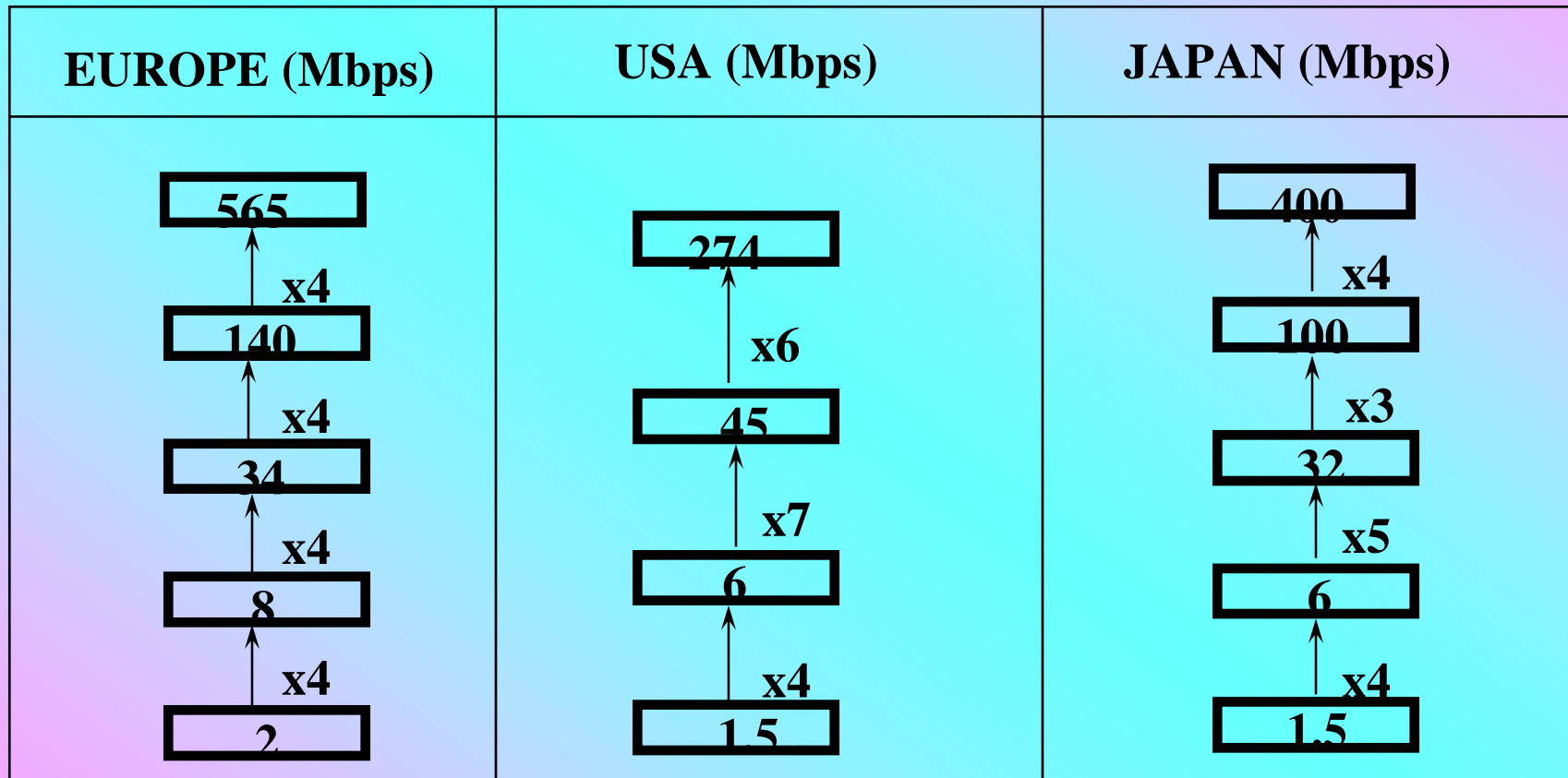

LIMITATIONS OF PDH

- **NON STANDARD EXPERIENCES:**

- THREE DIFFERENT HIERARCHIES WITH DIFFERENT SIGNAL FORMATS AND LINE ENCODING METHODS.**

- **BASIS OF TODAY'S HIGH CAPACITY NETWORK**

- ELABORATE ARRANGEMENT FOR DROPPING**

- **NETWORK REQUIREMENT**

- CHANGING REQUIREMENT**

BASIS OF TODAY'S NETWORK

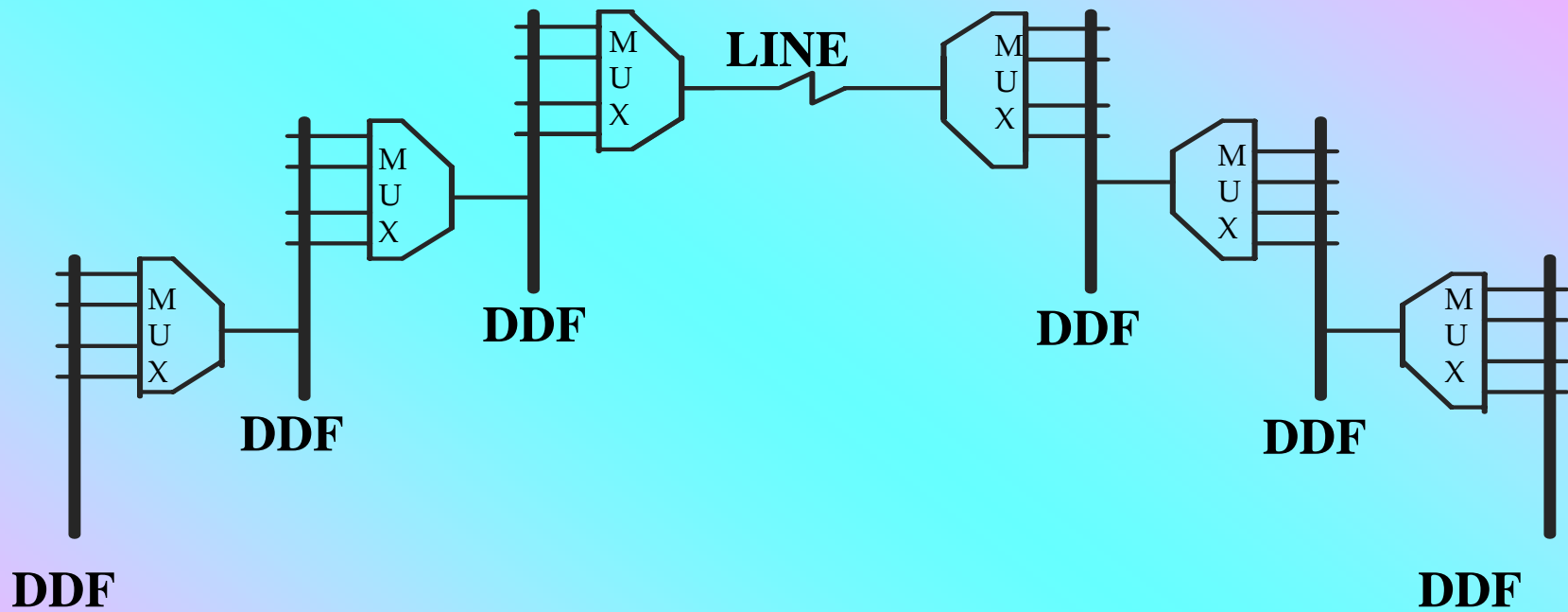

- **ELABORATE DROPPING ARRANGEMENT**

LIMITATIONS OF PDH

- **NON STANDARD EXPERIENCES:**

- THREE DIFFERENT HIERARCHIES WITH DIFFERENT SIGNAL FORMATS AND LINE ENCODING METHODS.**

- **BASIS OF TODAY'S HIGH CAPACITY NETWORK**

- ELABORATE ARRANGEMENT FOR DROPPING**

- **NETWORK REQUIREMENT**

- CHANGING REQUIREMENT**

CHANGING NETWORK REQUIREMENT

Yesterday's → NETWORK

POINT-TO-POINT
TRANSMISSION

SUPPORTED BY

MANUAL APPROACH
TO NETWORK
MANAGEMENT AND
MAINTENANCE.

CUSTOMER'S → NEED

FASTER PROVISIONING
OF CIRCUITS AND
SERVICES

&

DEMANDS FOR
SOPHISTICATED
TELECOM SERVICES

Today's NETWORK

TELECOMMUNICATION
NETWORKING

SUPPORTED BY

COMPUTER BASED
INTEGRATED
NETWORK MANAGEMENT
MAINTENANCE

SDH- ADVANTAGES

SIMPLIFICATION (ABILITY TO DIRECTLY DROP LOWER TRIB)

**CAN ACCOMMODATE BOTH EXISTING AND FUTURE SIGNALS
IMPROVED SERVICE QUALITY (THROUGH SUPERVISION)**

ADVANCED N/W MANAGEMENT AND MTCE CAPABILITIES.

N/W SURVIVABILITY

DYNAMIC N/W CAPACITY MANAGEMENT

MULTI VENDOR NETWORKING

SDH ACCOMMODATES EXISTING SIGNALS

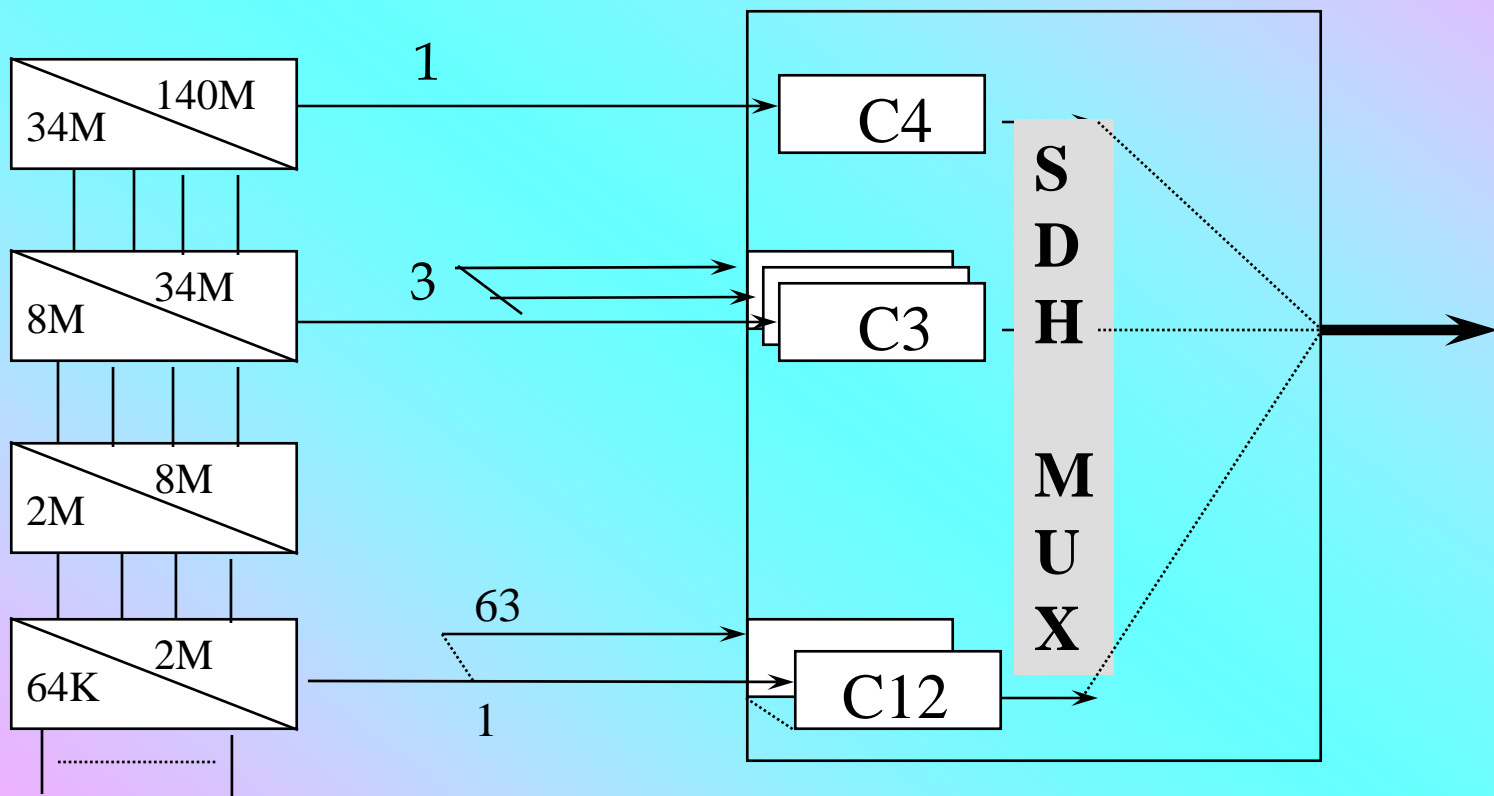

SIGNAL HIERARCHY

SONET vs SDH BIT RATES

SONET			SDH
SYNCHRONOUS TRANSPORT SIGNAL	OPTICAL CARRIER	BIT RATE MBPS	SYNCHRONOUS TRANSPORT MODULE
STS-1	OC-1	51.84	----
STS-3	OC-3	155.52	STM-1
STS-9	OC-9	466.56	----
STS-12	OC-12	622.08	STM-4
STS-18	OC-18	933.12	---
STS-24	OC-24	1244.16	---
STS--36	OC-36	1866.24	---
STS-48	OC-48	2488.32	STM-16
STS-192	OC-192	9953.28	STM-64

***BIT RATES FOR HIGHER ORDER IS N-TIMES THE LOWER ORDER**

REDUCED MUX STRUCTURE

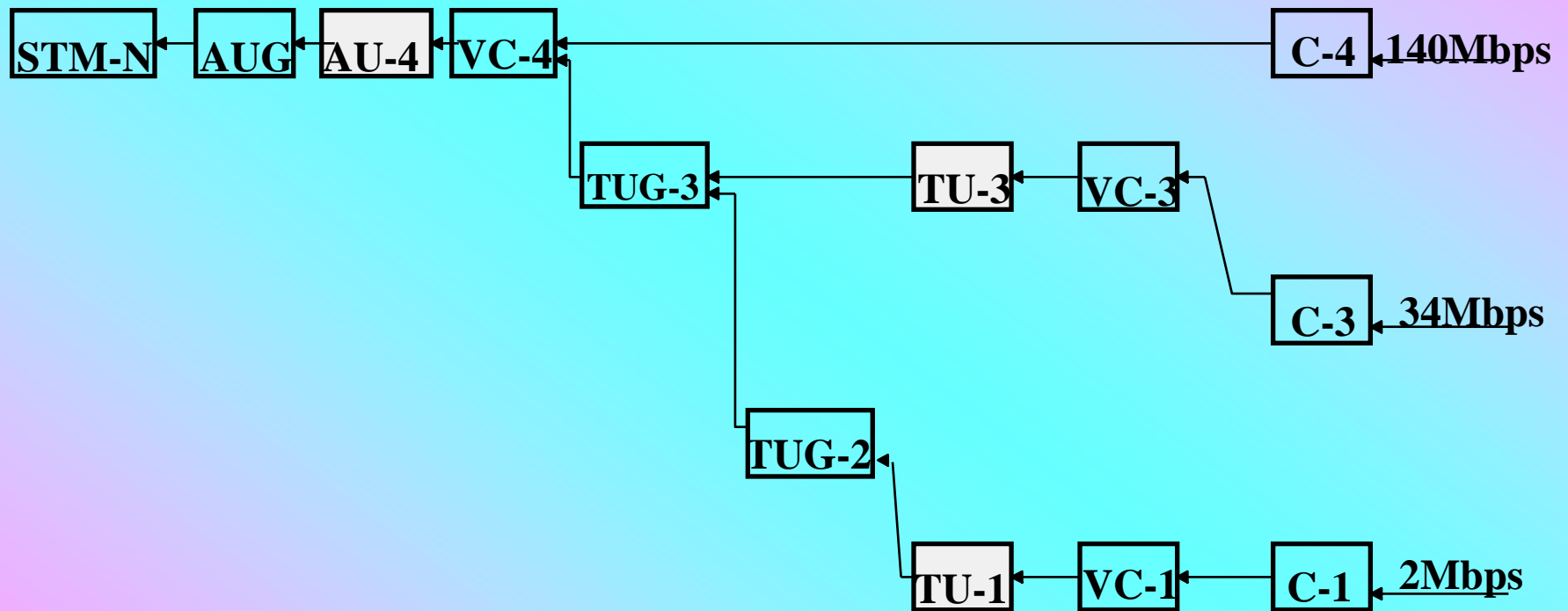

(REDUCED DIAGRAM FOR SDH-MULTIPLEXING)

MUX PRINCIPLE

Container-n(n=1-4): A container is the information structure which forms the network synchronous information payload for a virtual container

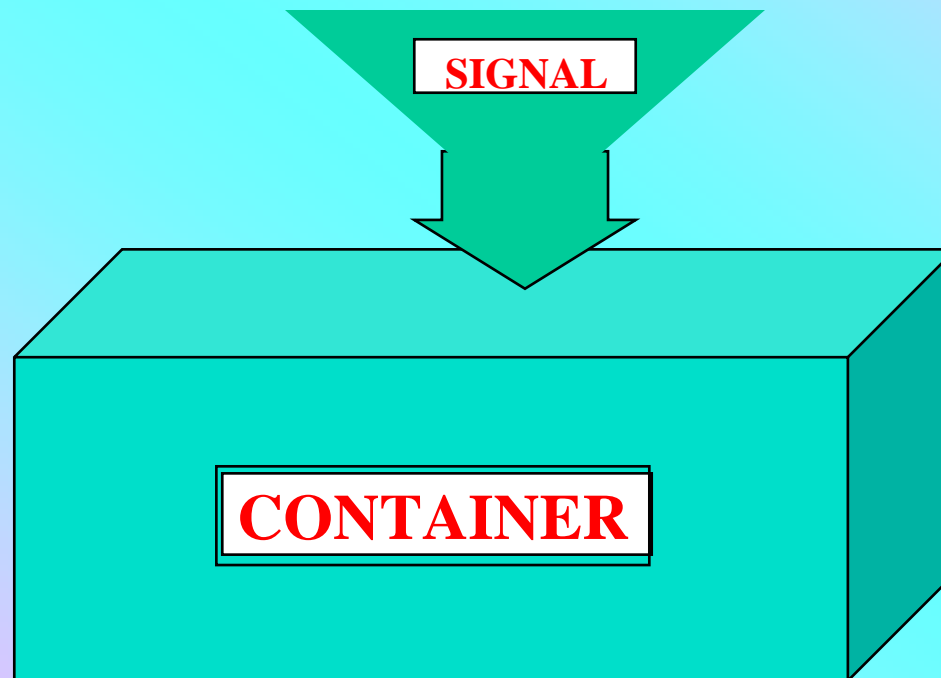

MUX PRINCIPLE: CONTAINERS(C-n)

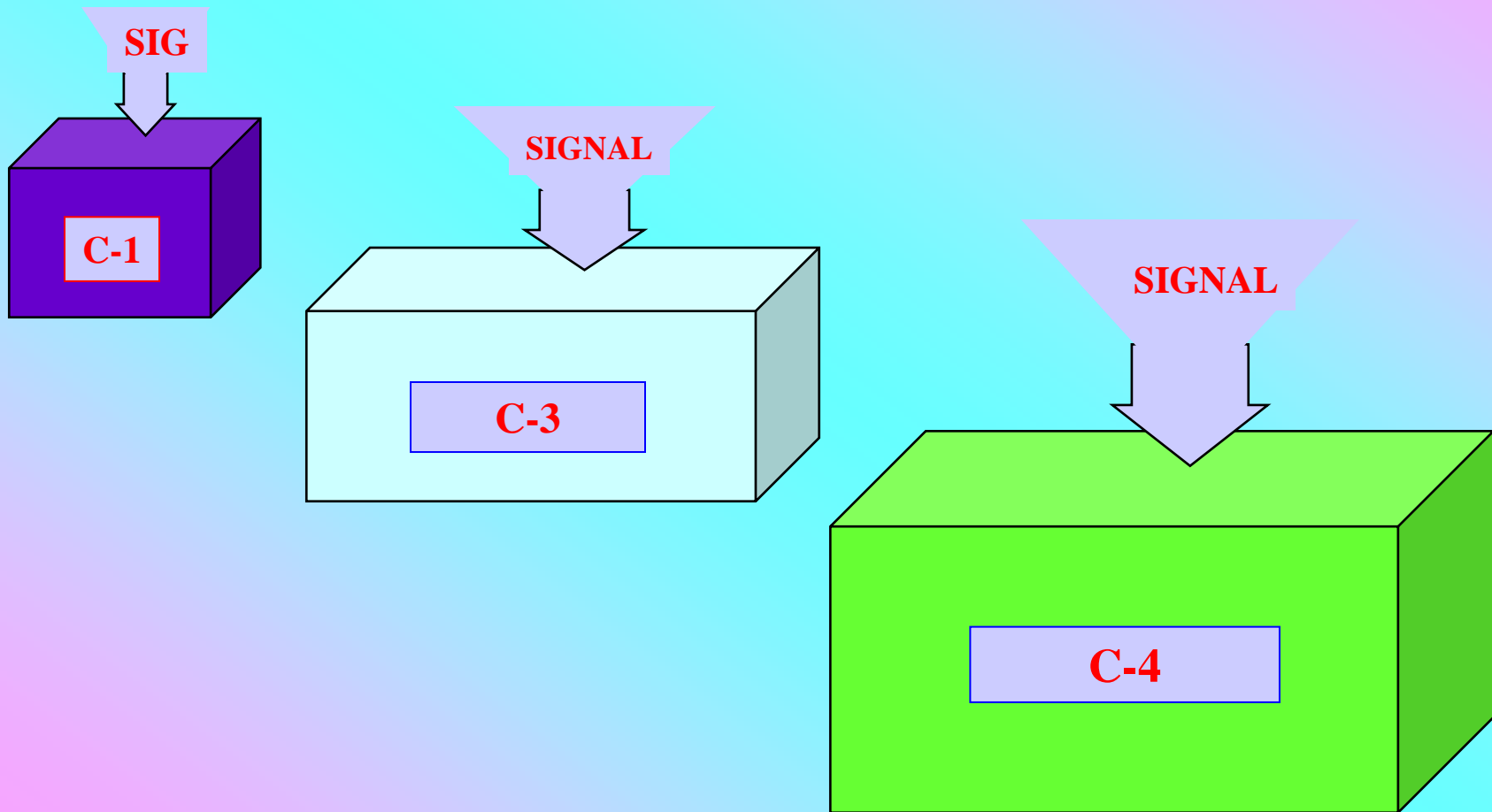

MUX PRINCIPLE: VC-n

Virtual Container-n(VC-n): It is the information structure used to support path layer connections in the SDH.

Two types of VCs: Lower order VC-n(n=1,2)
Higher order VC-n(n=3,4)



MUX PRINCIPLE: TU-n/ AU

- It is an information structure which provides adaptation between two layers:
 - Between lower and higher order path layers for TU
 - Between higher order path layer and section layer for AU



POINTER is an indicator whose value defines the frame offset of a VC with respect to the frame reference of the transport entity on which it is supported

MUX PRINCIPLE: STM-1(from C-4)

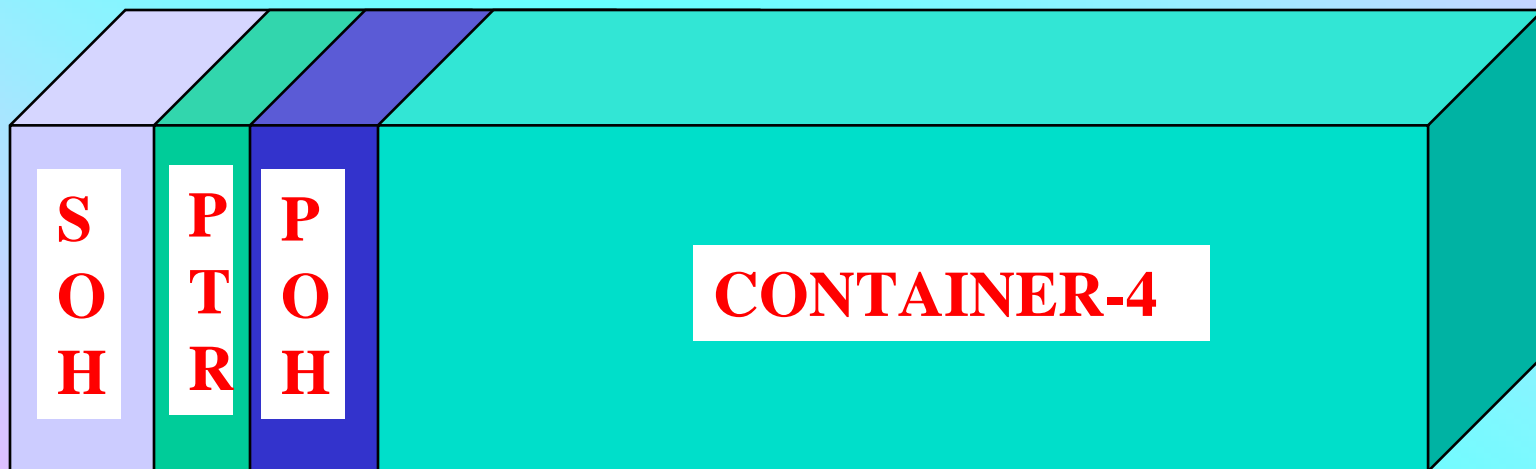

MULTIPLEXING FROM C-4

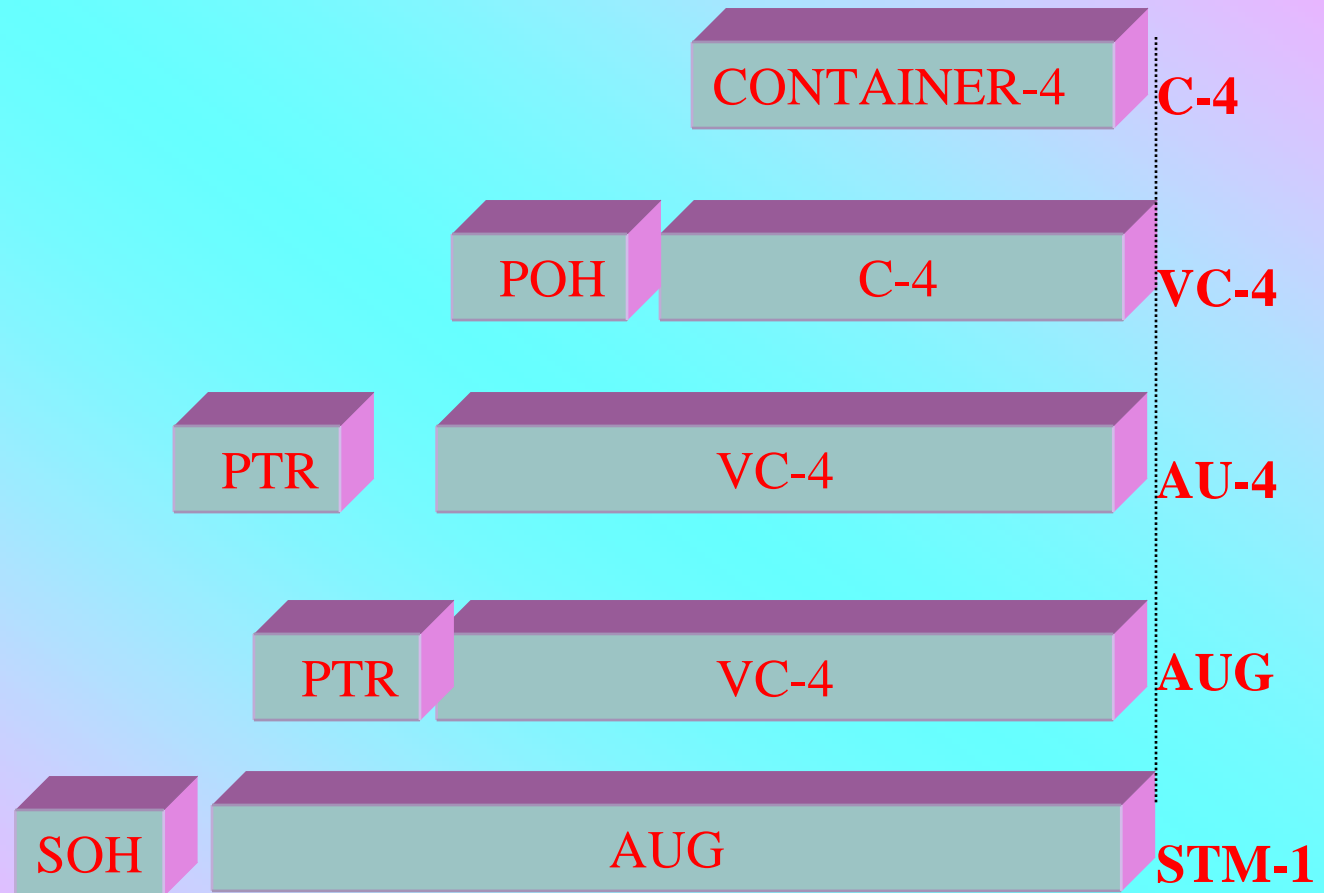

MUX PRINCIPLE: STM-1(from C-3)

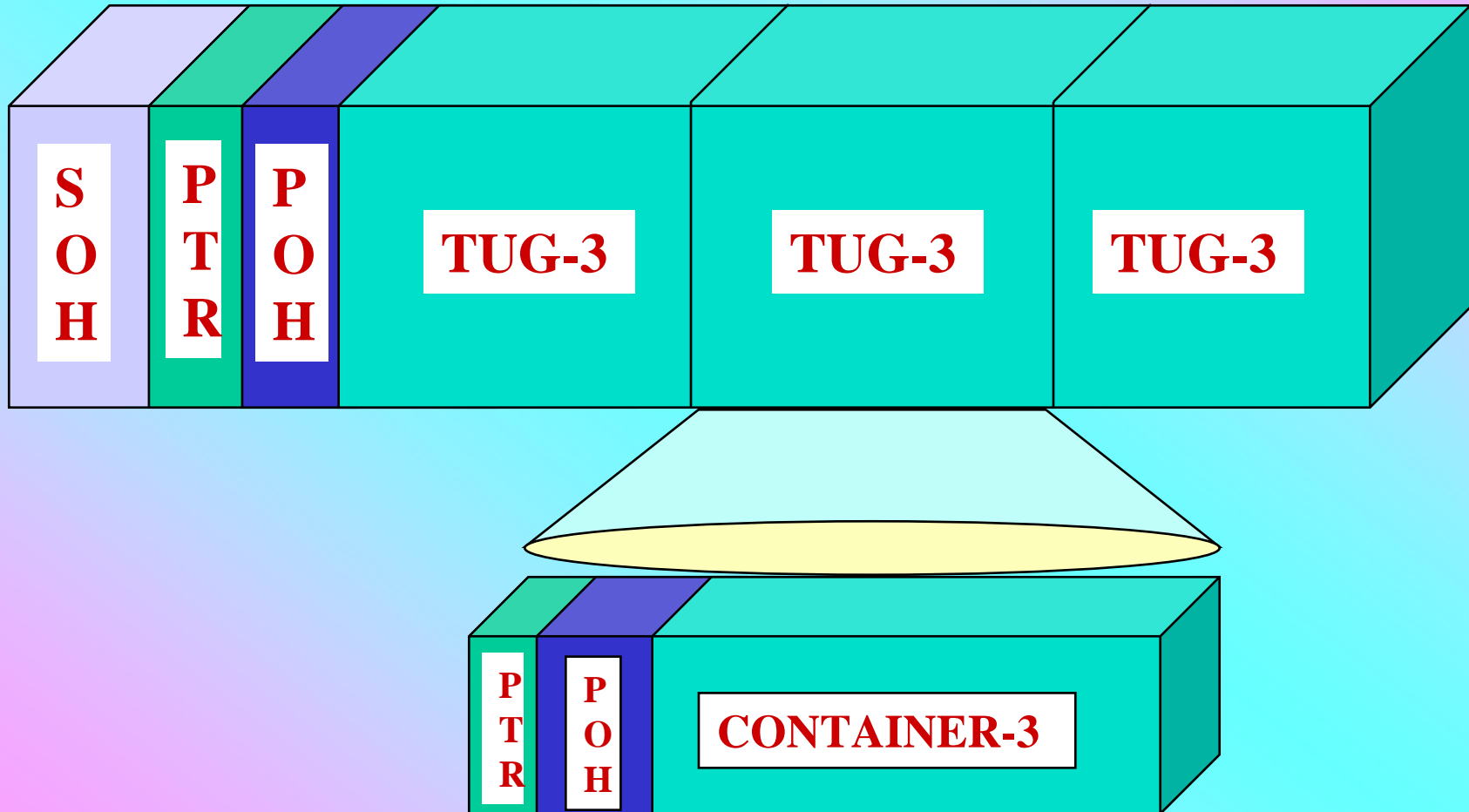

MUX PRINCIPLE: STM-1(from C-1)

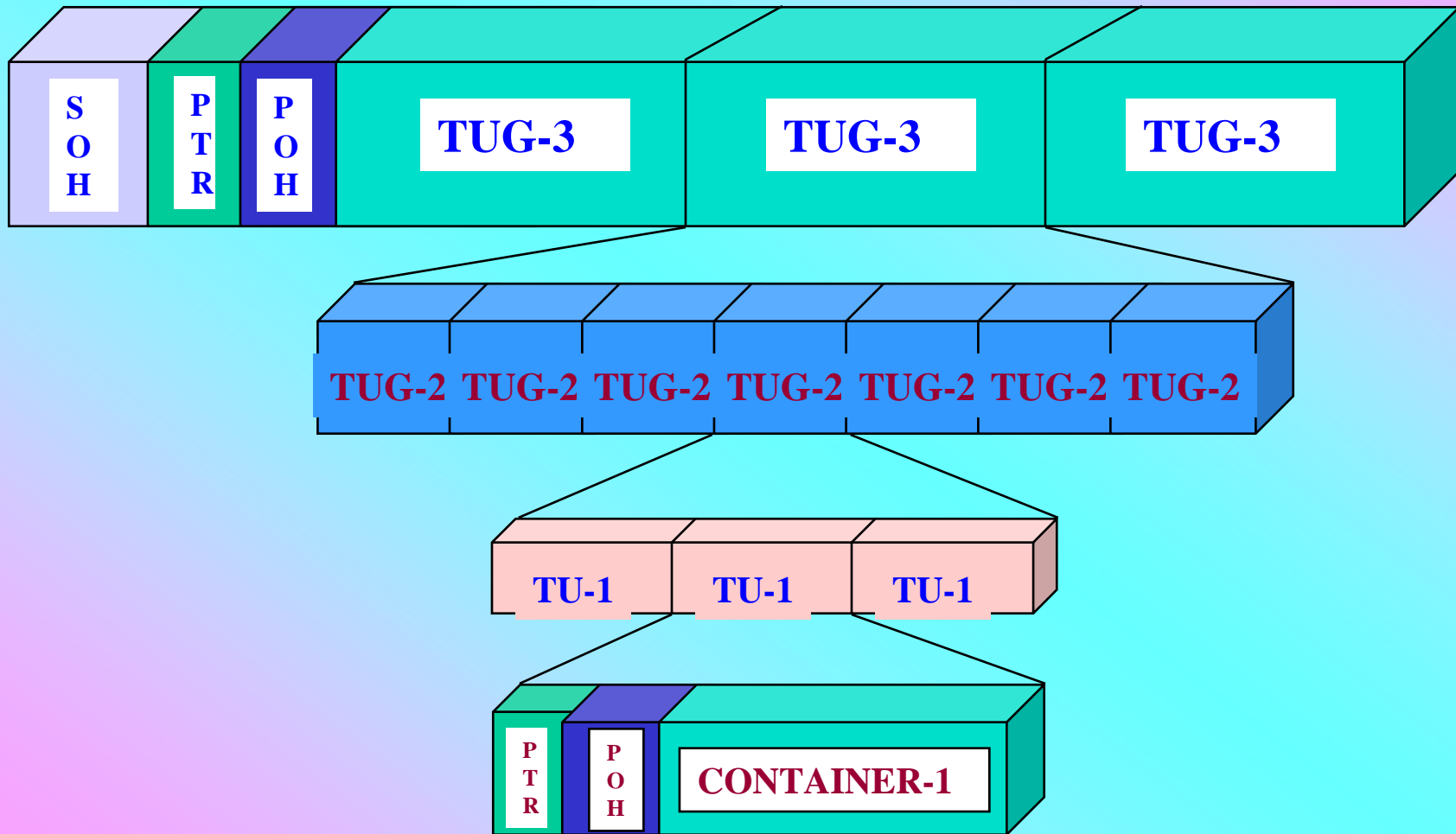

- The Container (C)
 - Basic packaging unit for tributary signals (PDH)
 - Synchronous to the STM-1
 - Bitrate adaptation is done via a positive stuffing procedure
 - Bit by bit stuffing
- The Virtual Container (VC)
 - Formation of the Container by adding of a POH (Path Overhead)
 - Transport as a unit through the network (SDH)
 - A VC containing several VCs has also a pointer area

- The Tributary Unit (TU)
 - Is formed via adding a pointer to the VC
- The Tributary Unit Group (TUG)
 - Combines several TUs for a new VC
- The Administrative Unit (AU)
 - Is shaped if a pointer is allocated to the VC formed at last
- The Synchronous Transport Module Level 1 (STM-1)
 - Formed by adding a Section Overhead (SOH) to AUs
 - Clock justification through stuffing in the AU pointer area
 - byte by byte stuffing

SDH FRAME REPRESENTATION

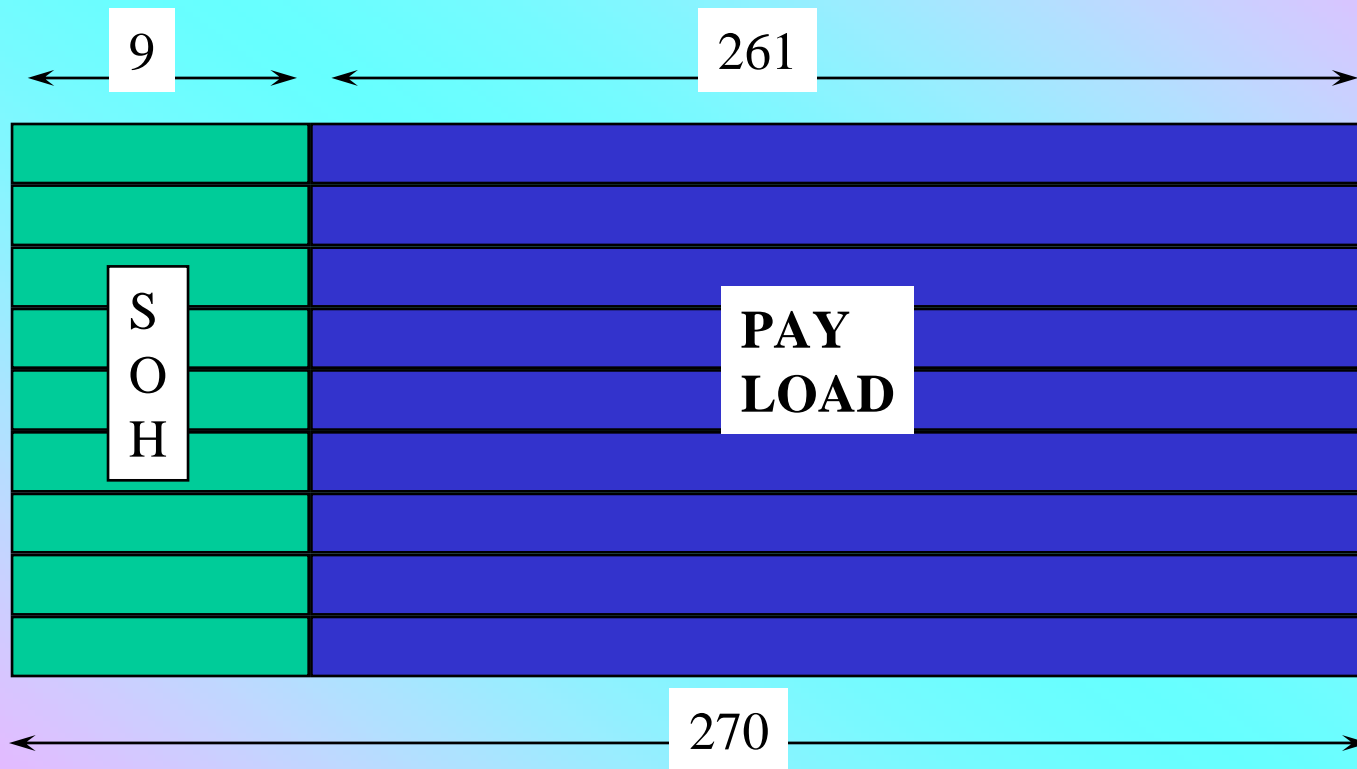

(MATRIX REPRESENTATION)

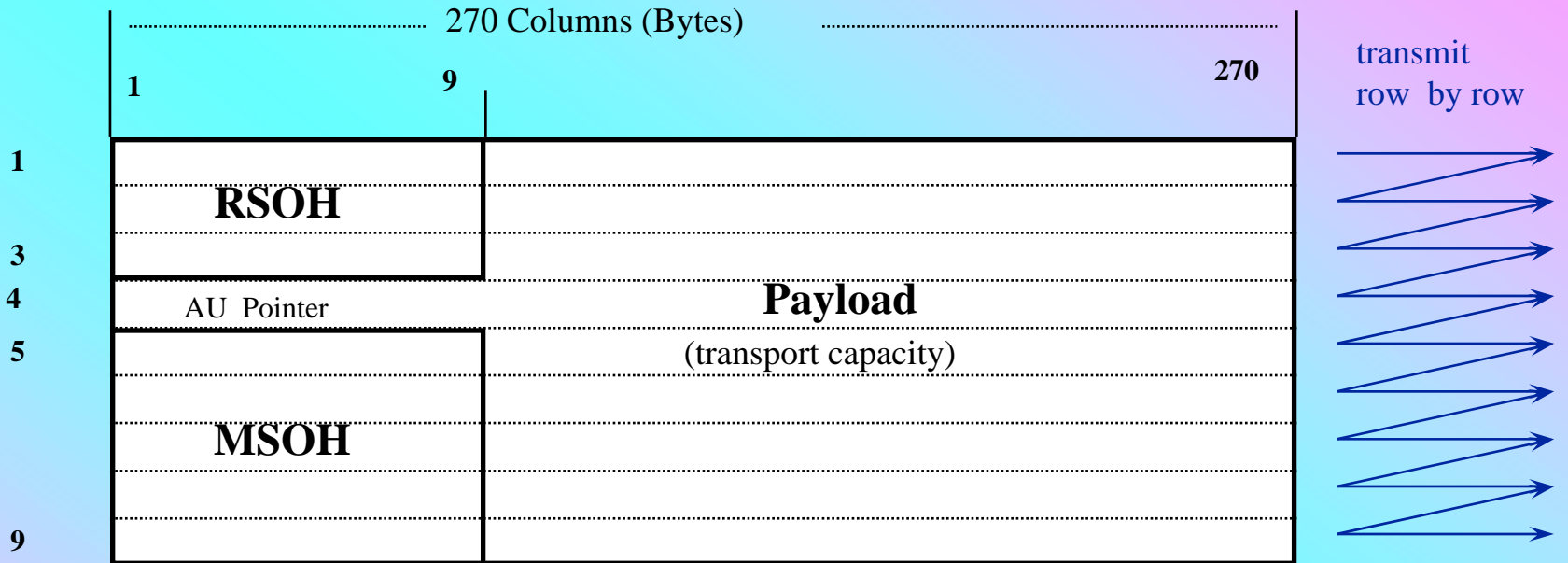

RSOH: Regenerator section overhead

MSOH: Multiplex section overhead

Payload: Area for information transport

Transport capacity of one Byte: 64 kbit/s

Frame capacity: $270 \times 9 \times 8 \times 8000 = 155.520$ Mbit/s

Frame repetition time: 125 μ s

THE TRUCK

OVERHEAD

PAYLOAD

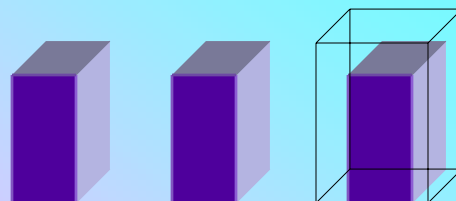
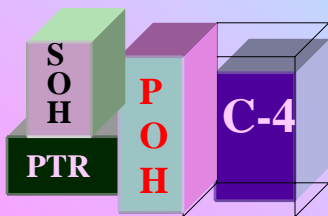
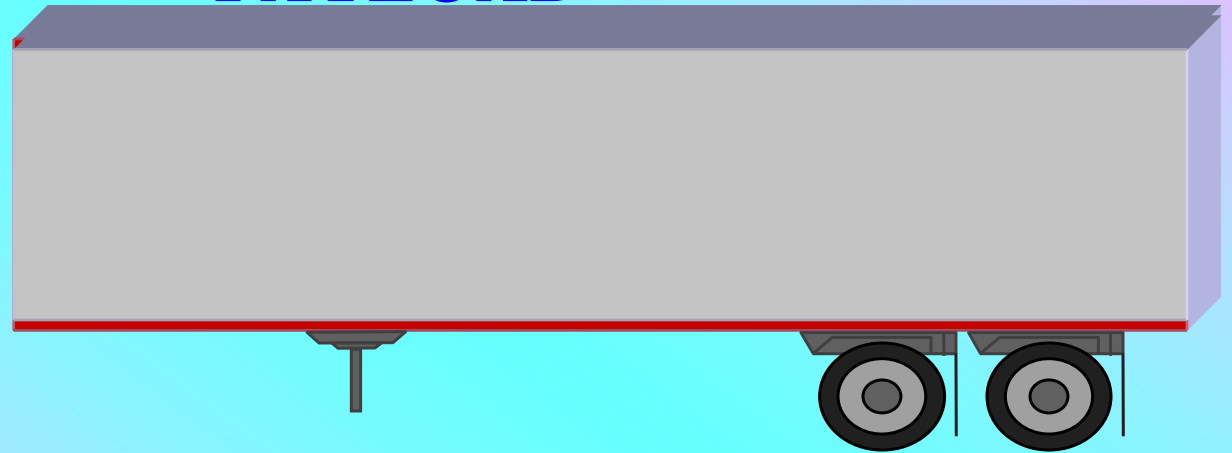
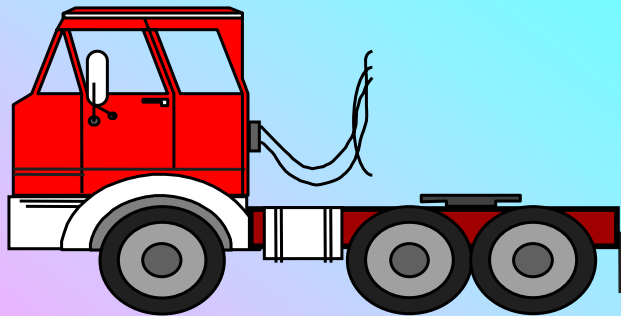

Thursday, December
01, 2005

ALTTC/TX1/SDH/CONCEPTS

FRAME REPRESENTATION

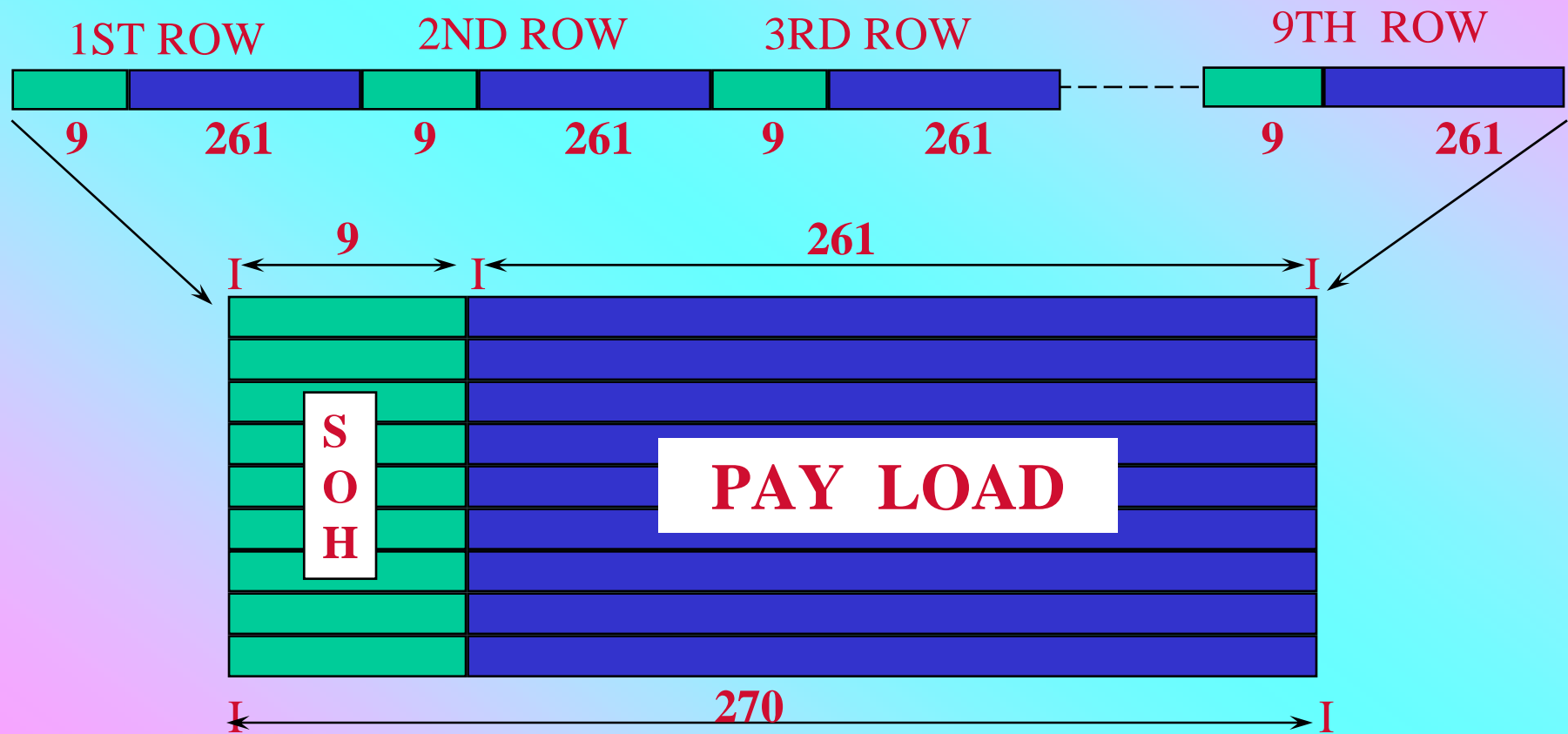

(MATRIX REPRESENTATION)

FRAME REPRESENTATION

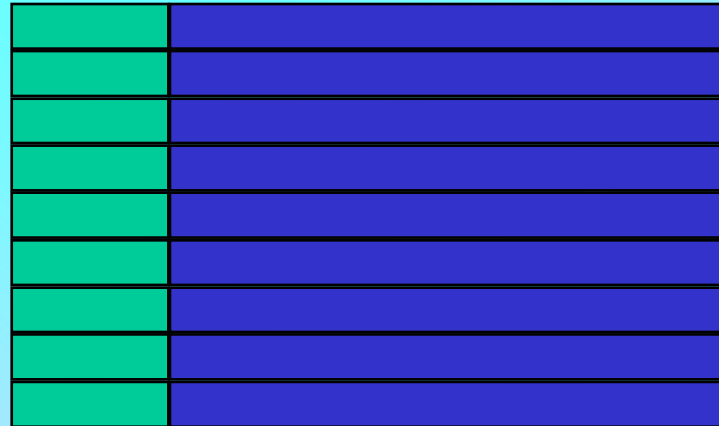

FRAME REPRESENTATION

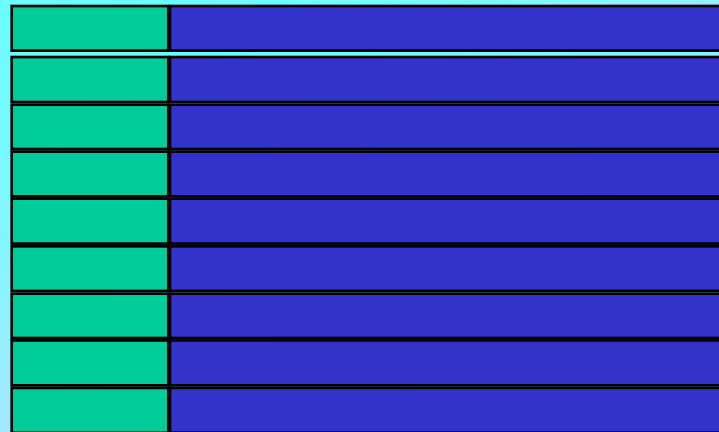

FRAME REPRESENTATION

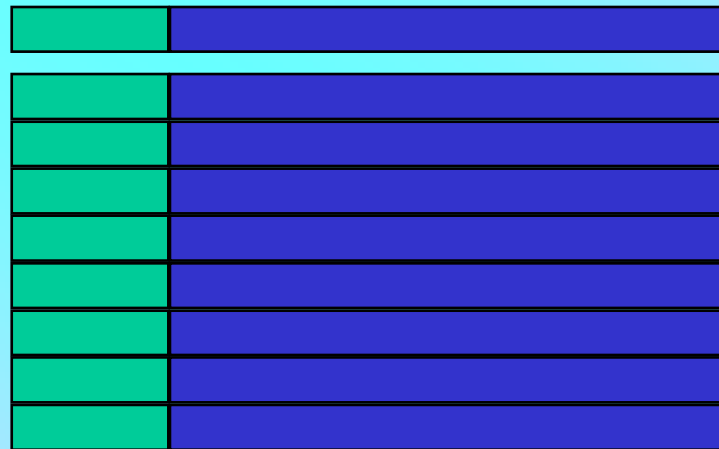

FRAME REPRESENTATION

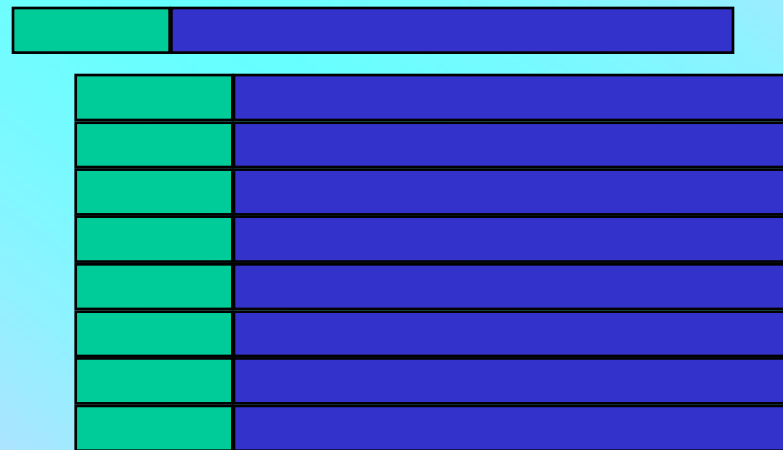

FRAME REPRESENTATION

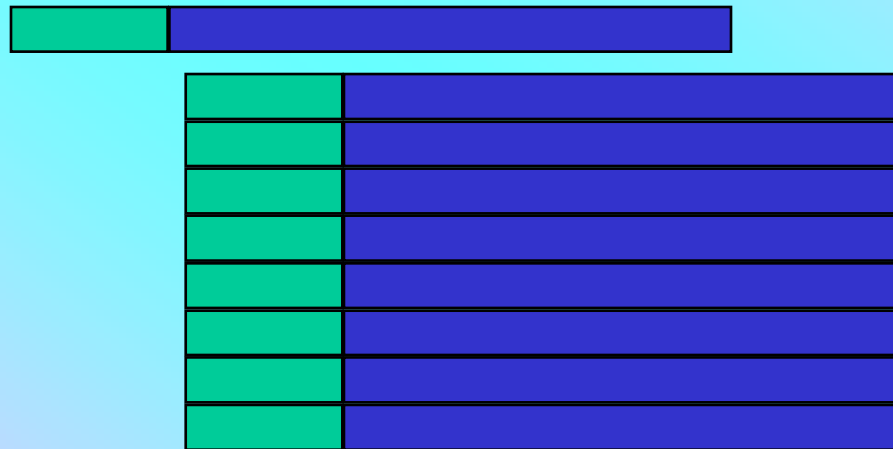

FRAME REPRESENTATION

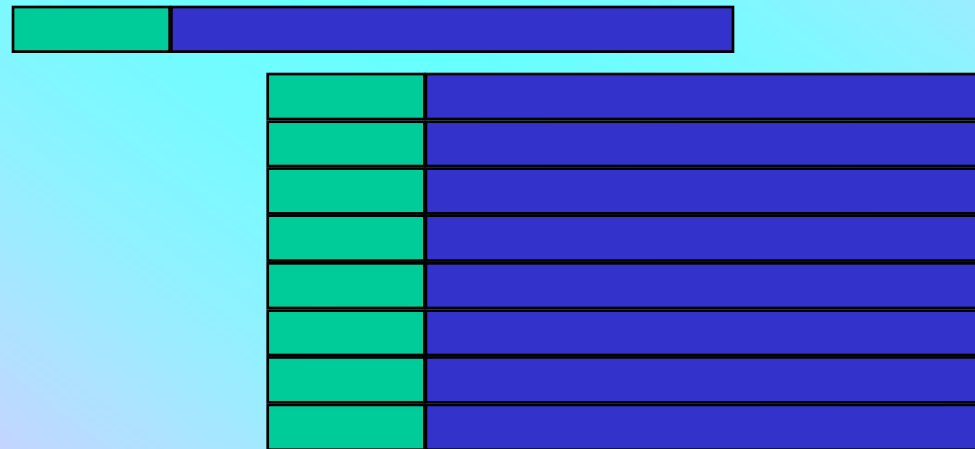

FRAME REPRESENTATION

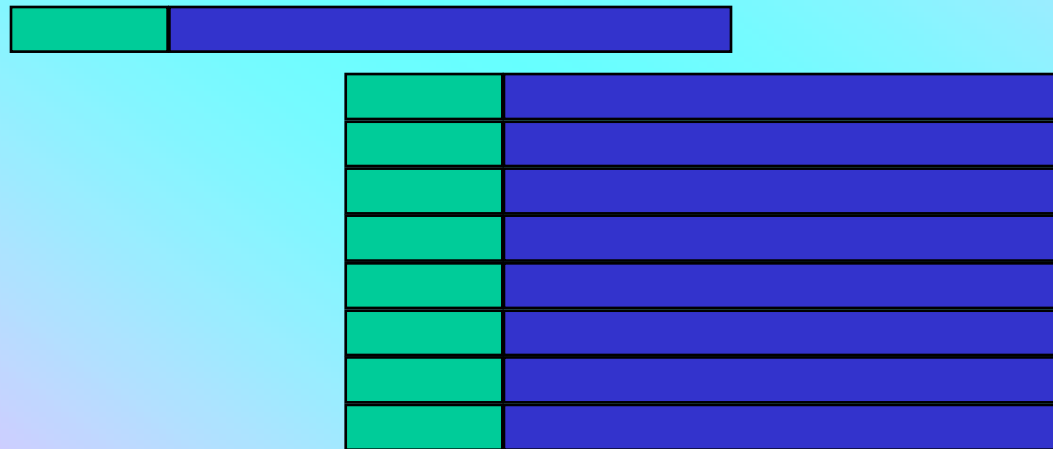

FRAME REPRESENTATION

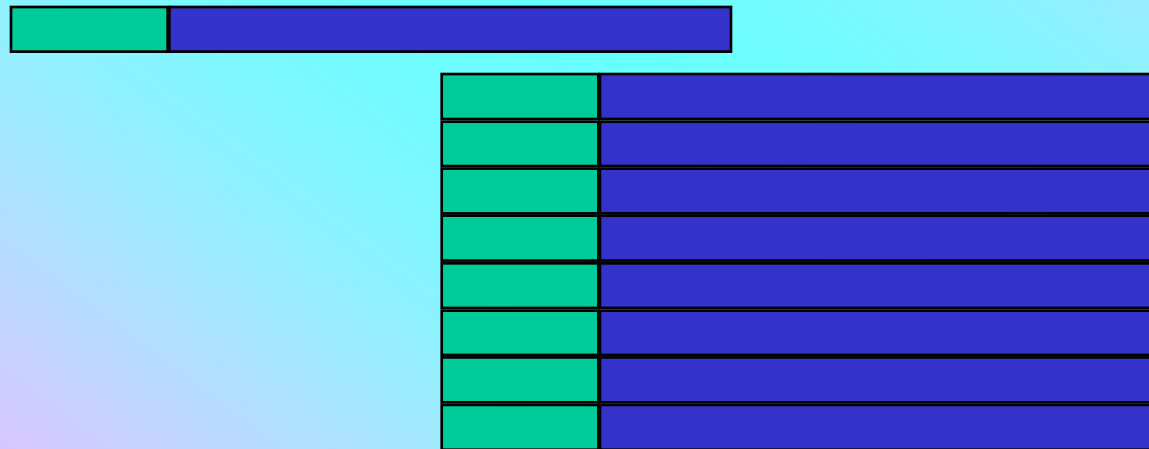

FRAME REPRESENTATION

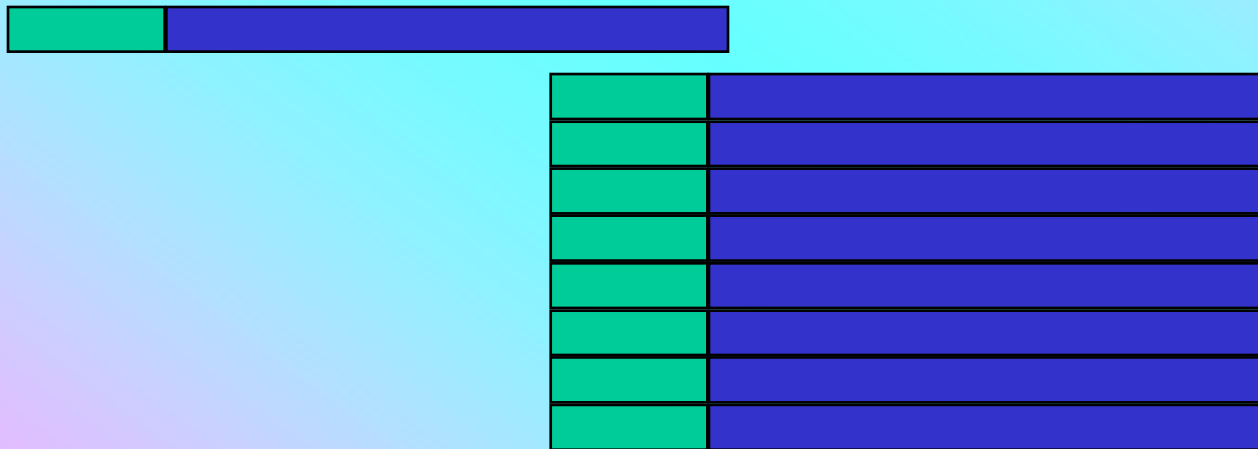

FRAME REPRESENTATION

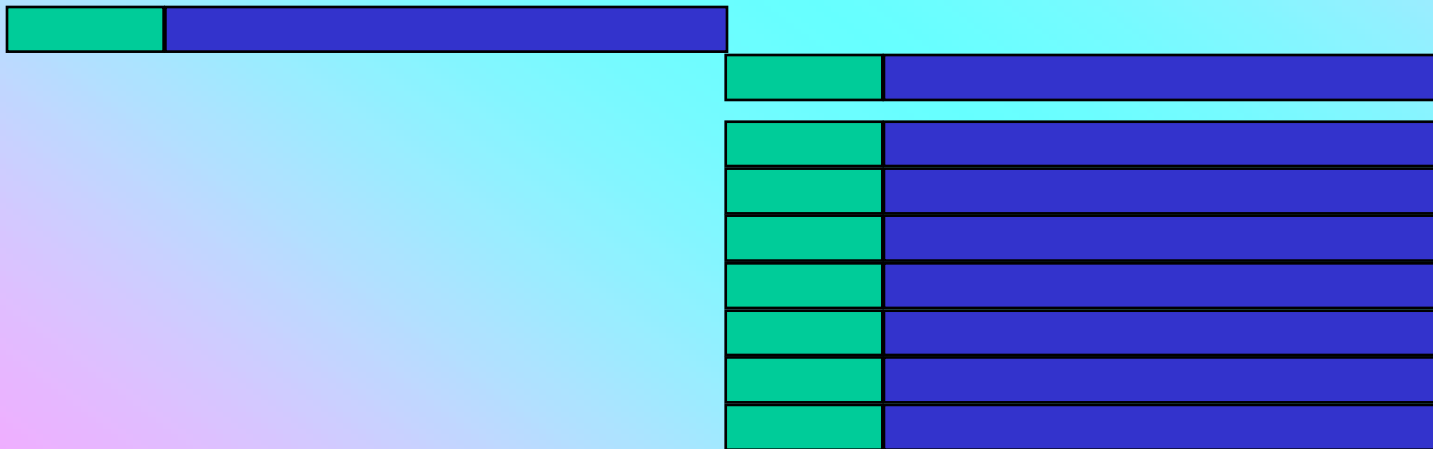

FRAME REPRESENTATION

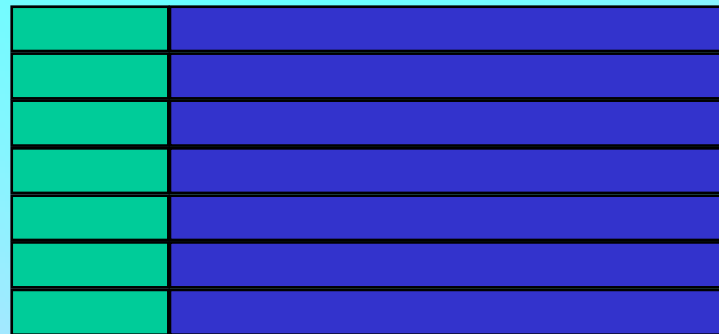

FRAME REPRESENTATION



FRAME REPRESENTATION

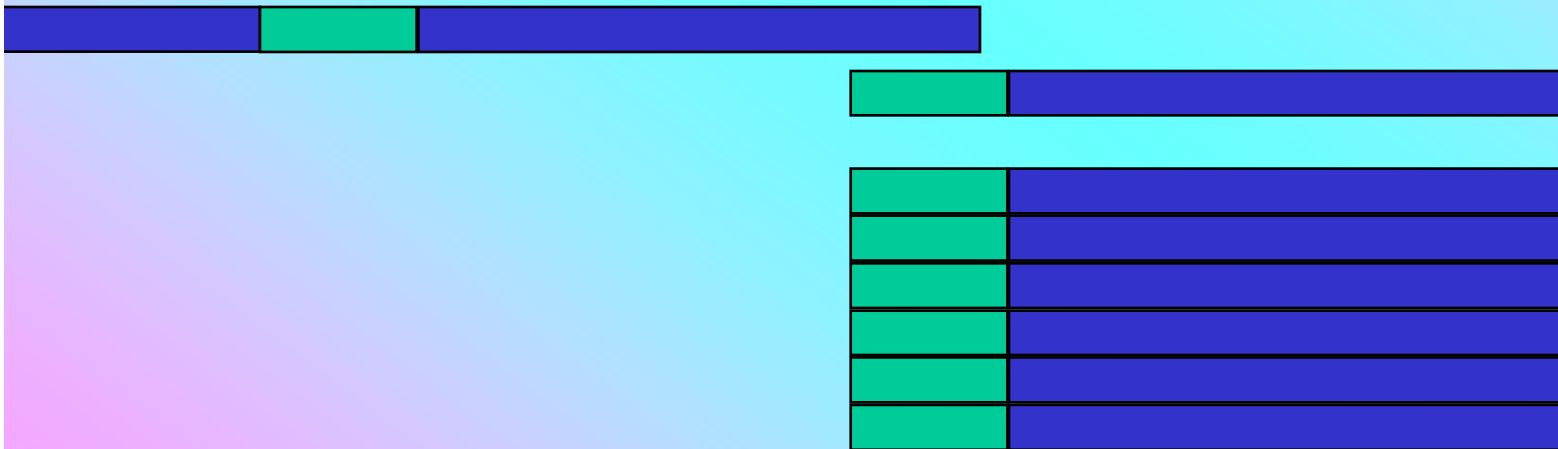

FRAME REPRESENTATION

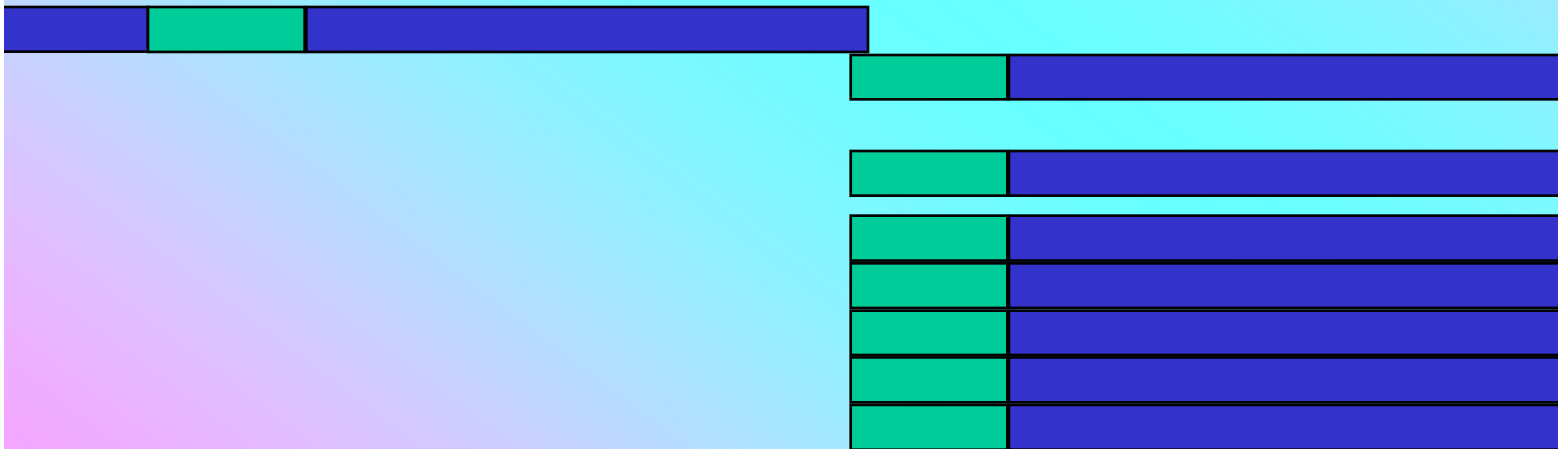

FRAME REPRESENTATION

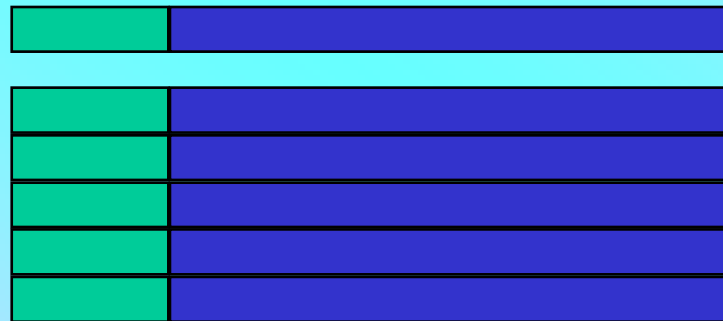

FRAME REPRESENTATION

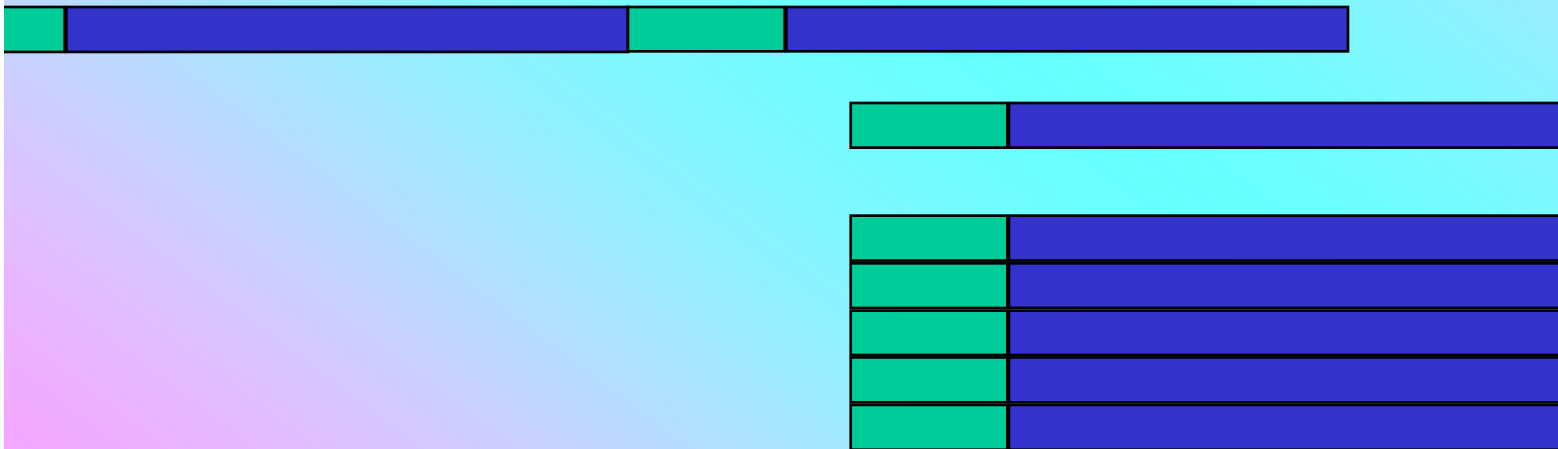

FRAME REPRESENTATION

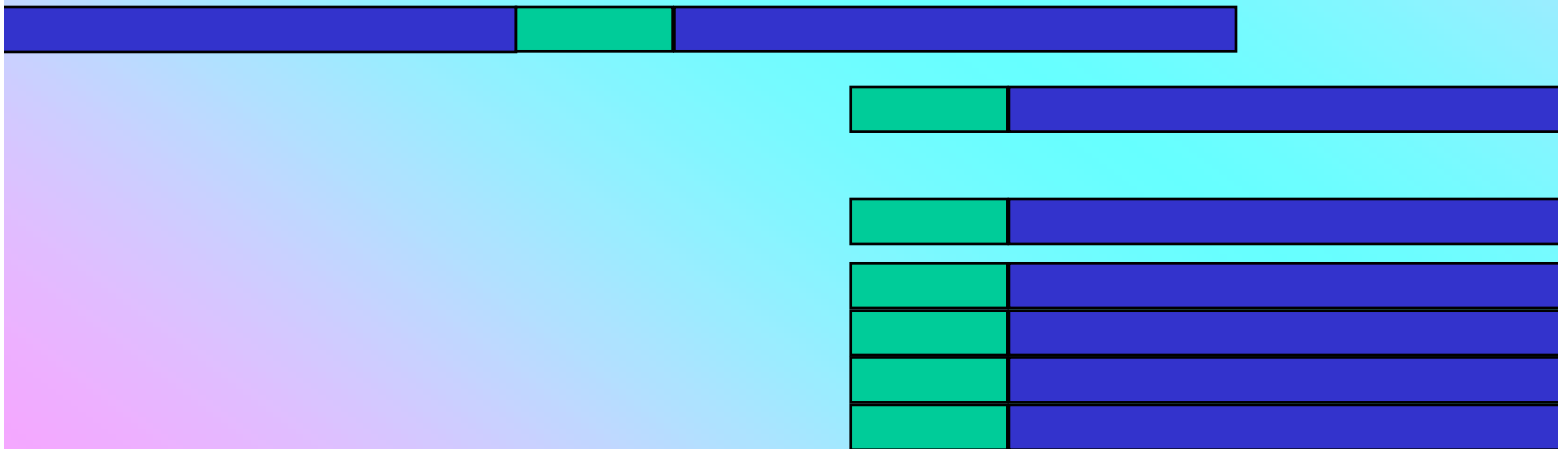

FRAME REPRESENTATION

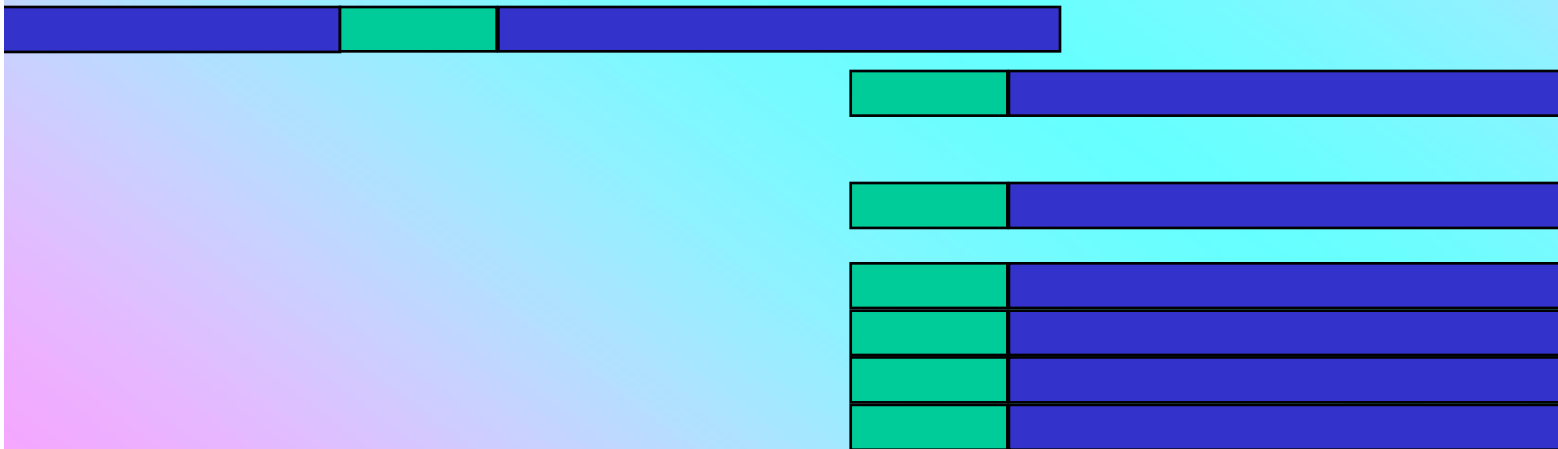

FRAME REPRESENTATION

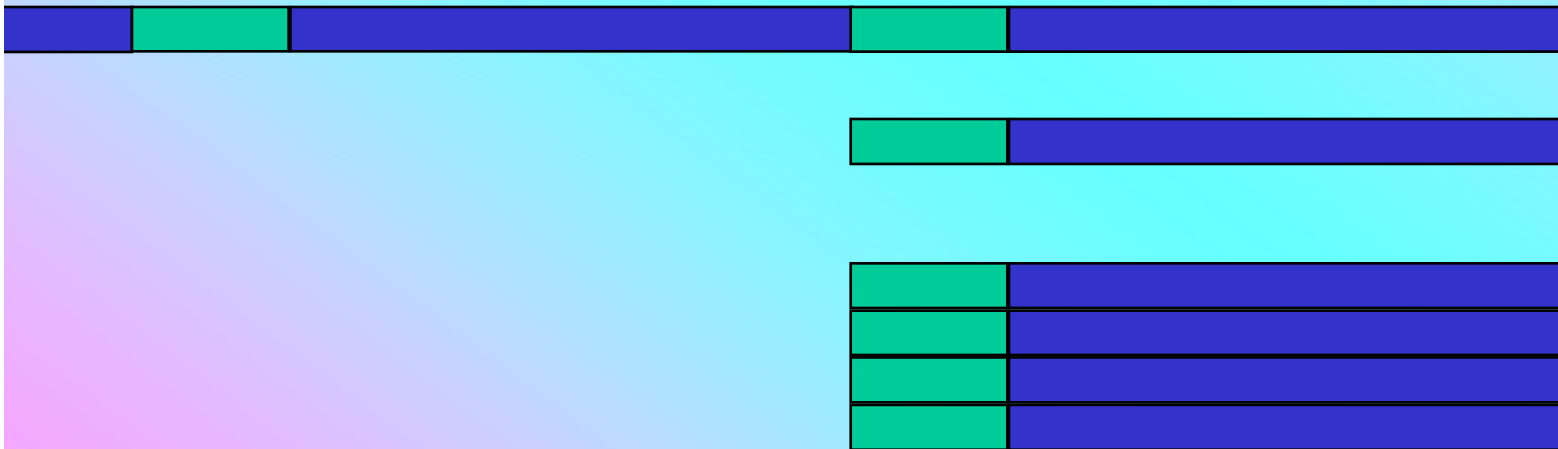

FRAME REPRESENTATION

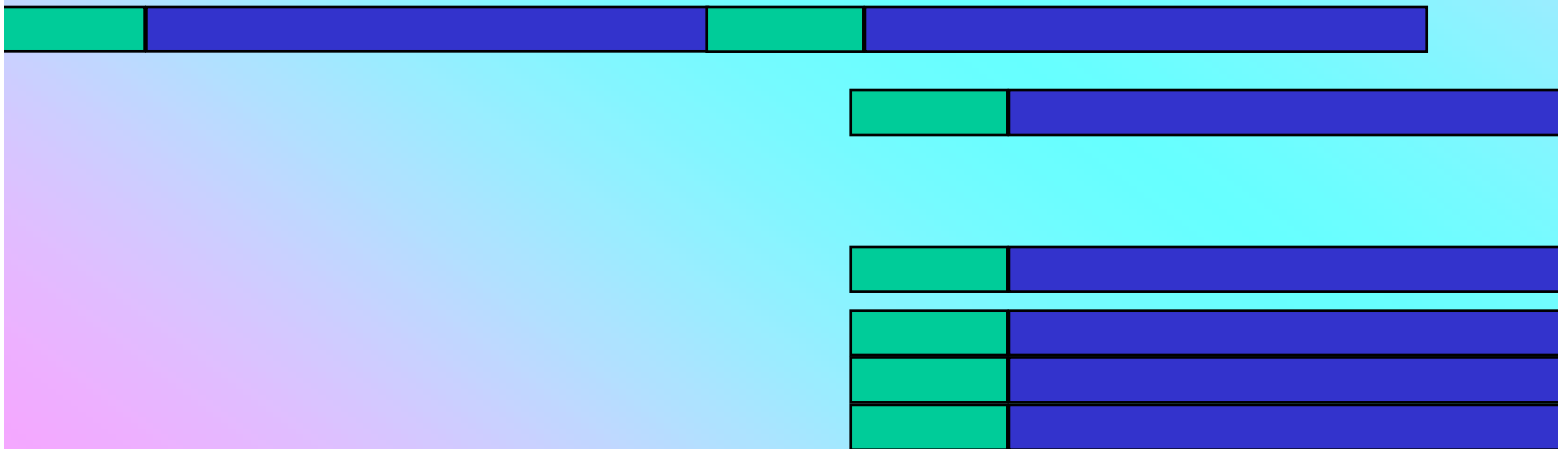

FRAME REPRESENTATION

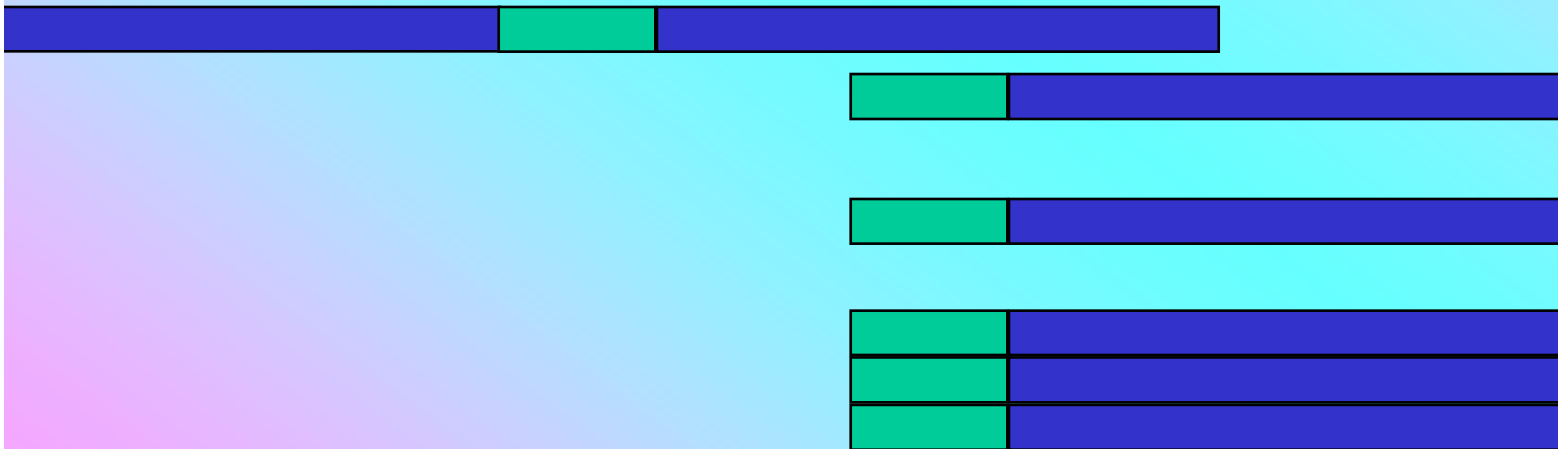

FRAME REPRESENTATION

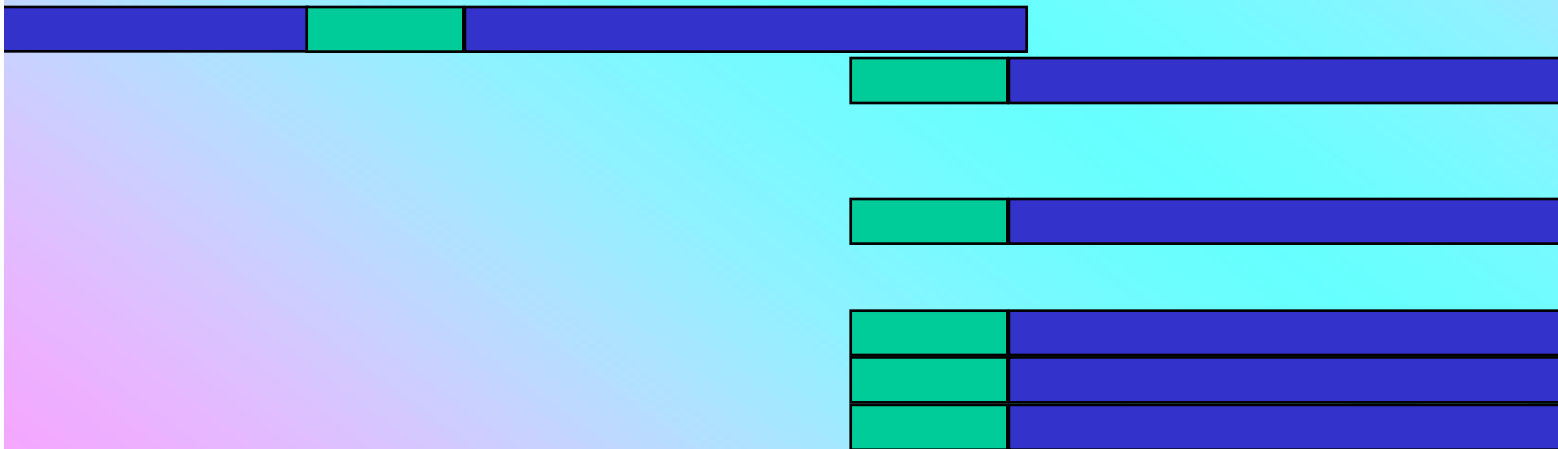

FRAME REPRESENTATION

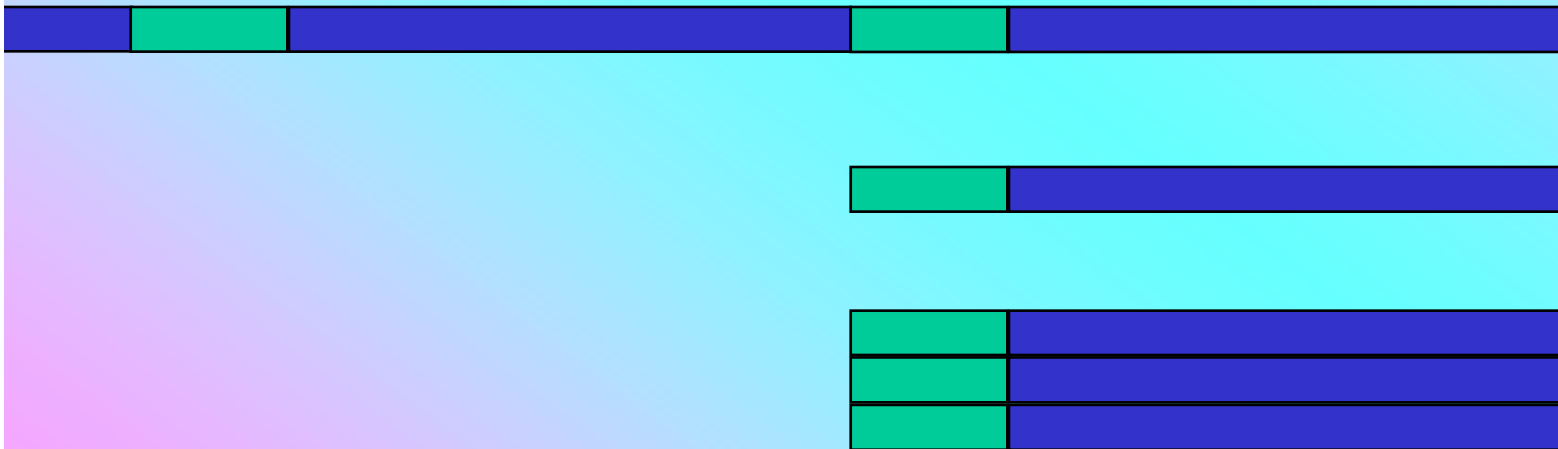

FRAME REPRESENTATION

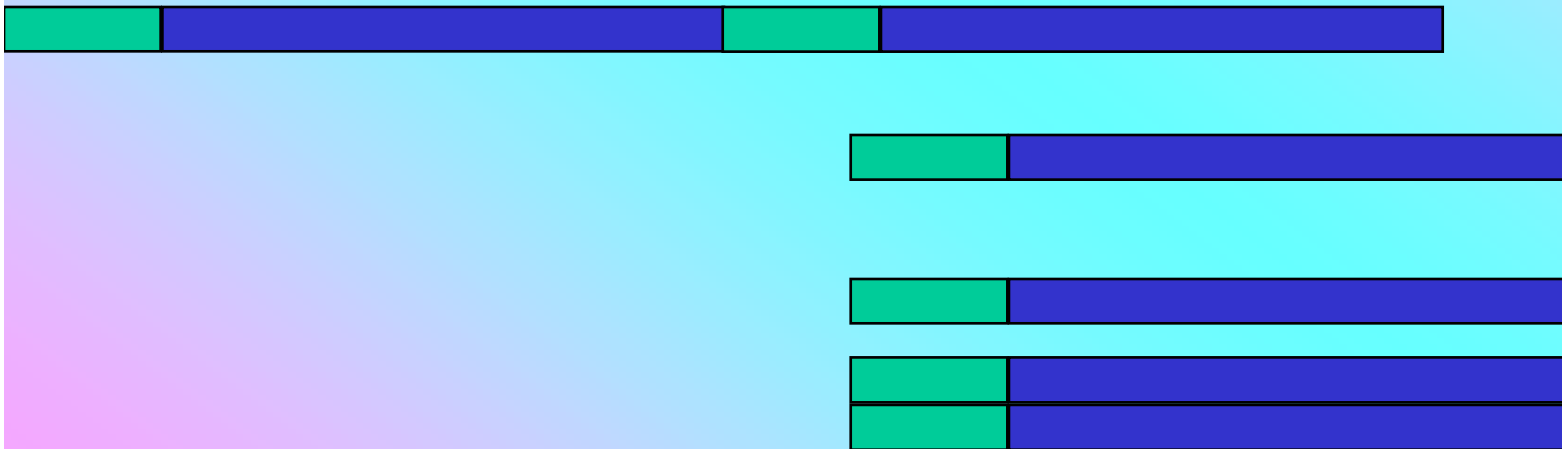

FRAME REPRESENTATION



FRAME REPRESENTATION

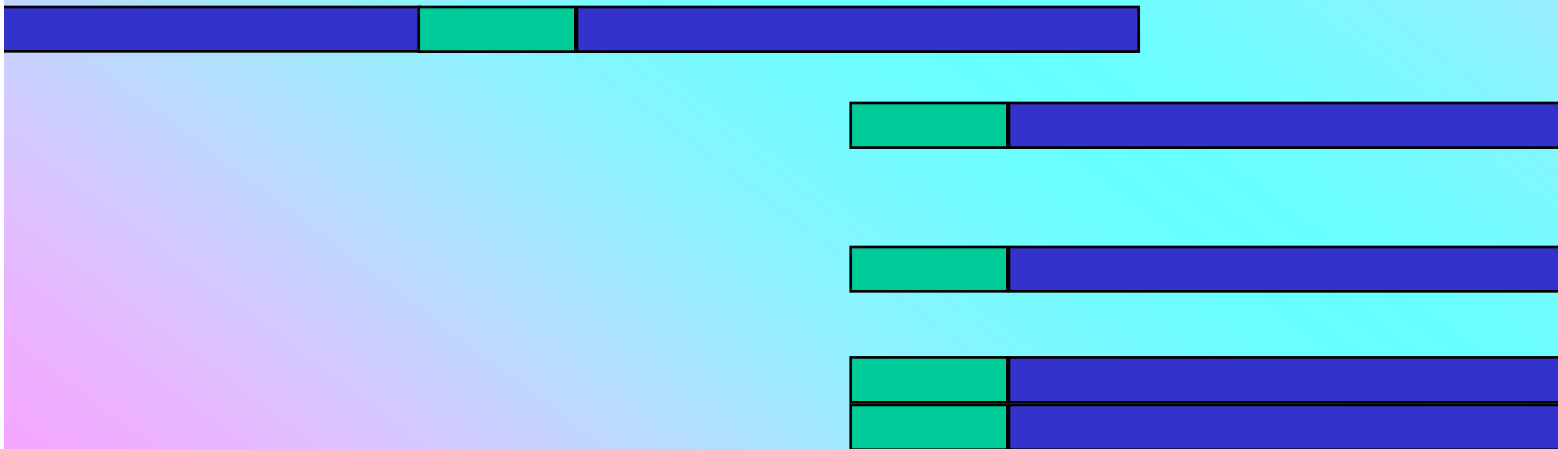

FRAME REPRESENTATION

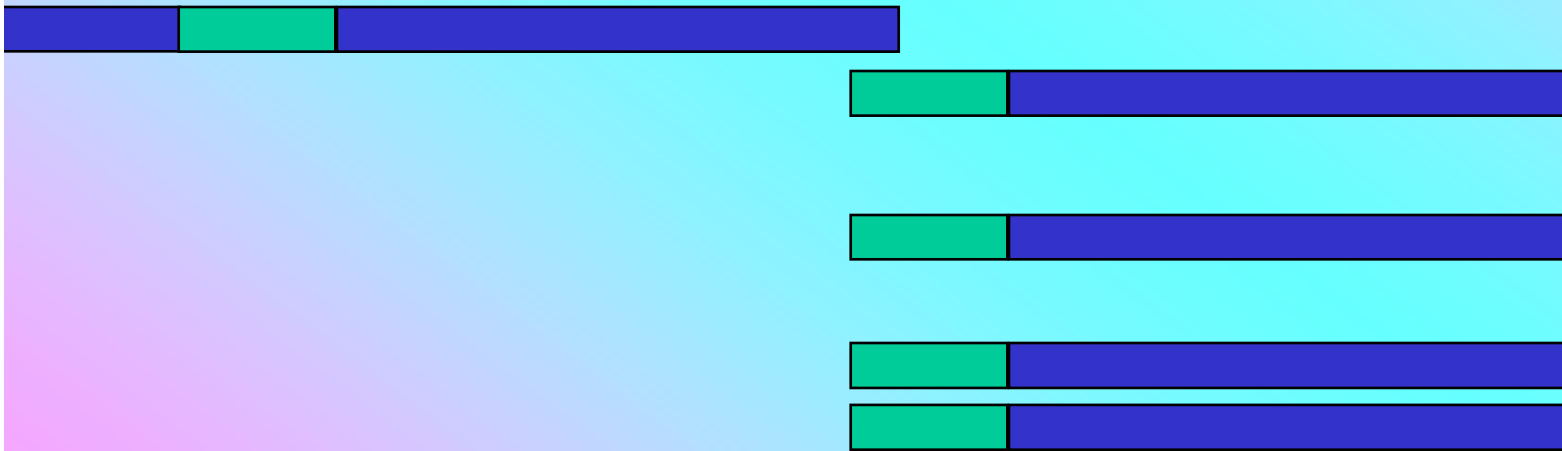

FRAME REPRESENTATION

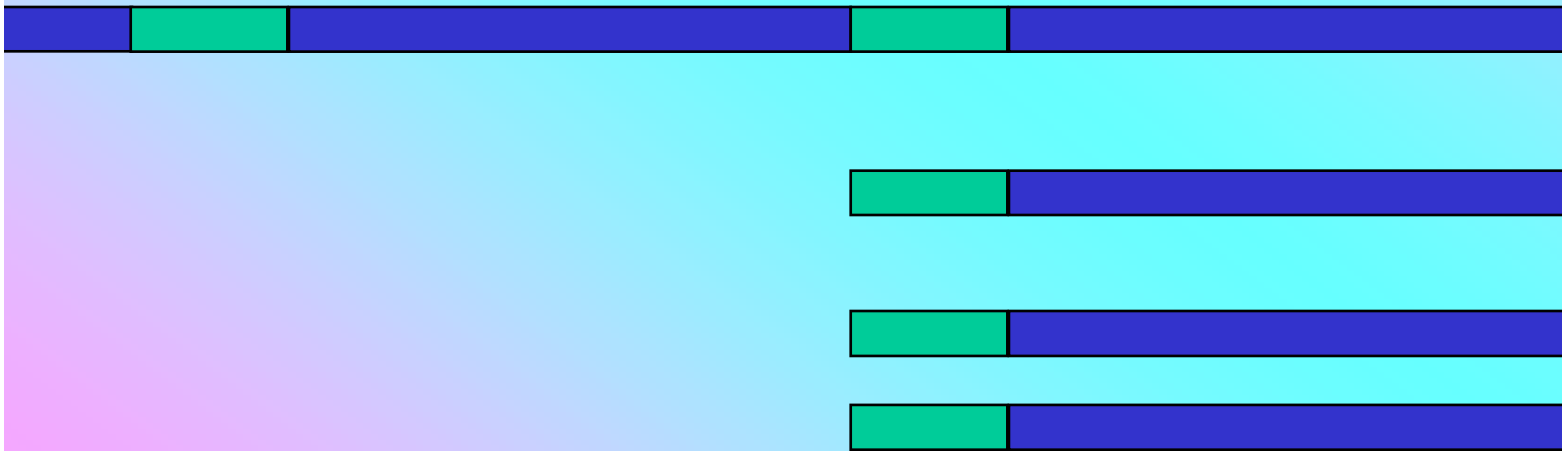

FRAME REPRESENTATION



FRAME REPRESENTATION



FRAME REPRESENTATION

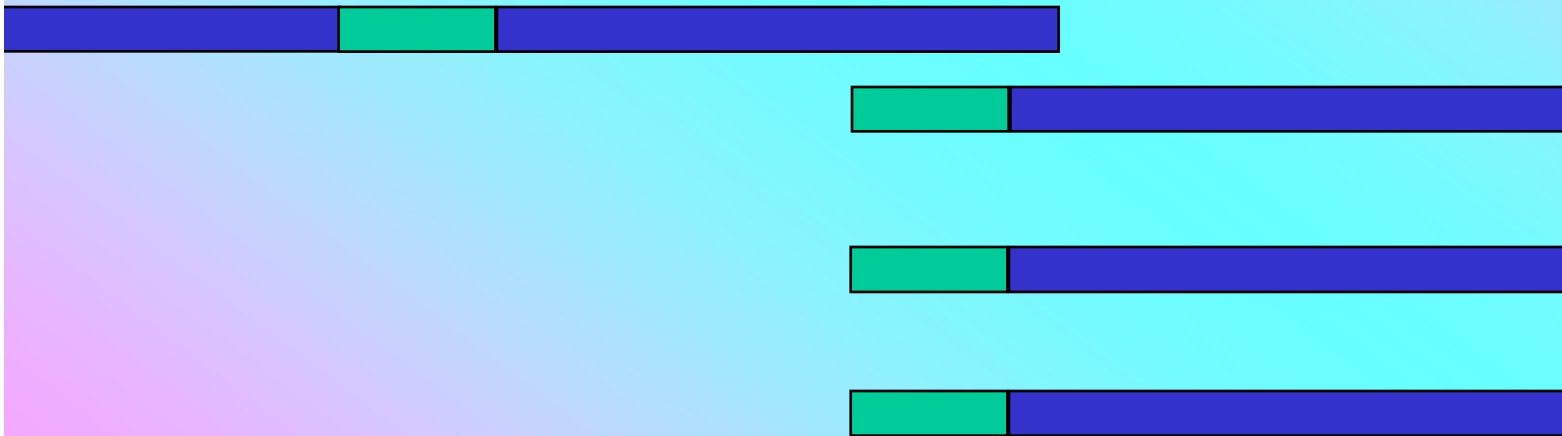

FRAME REPRESENTATION

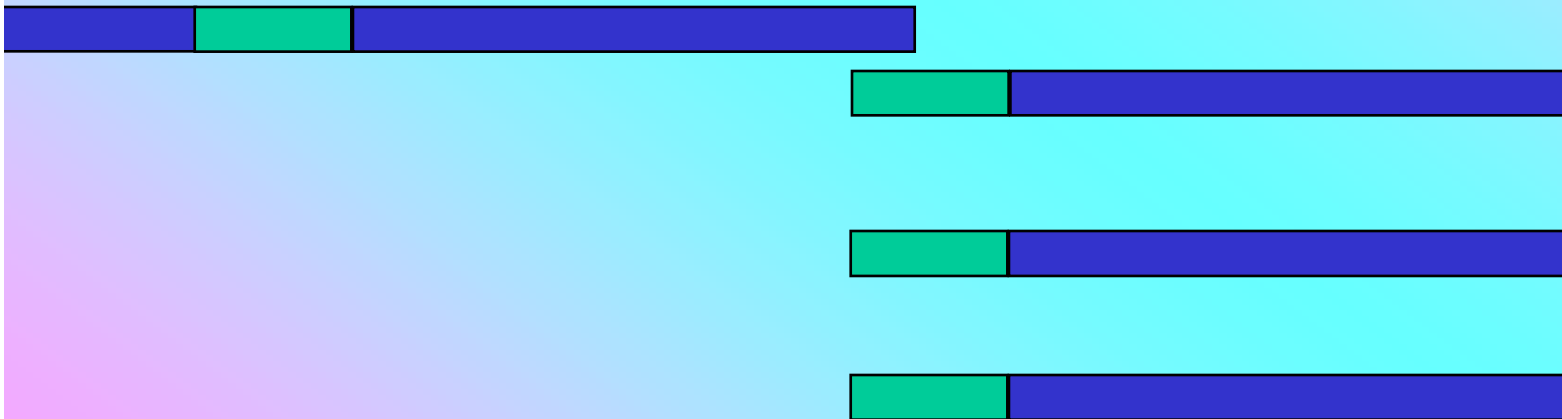

FRAME REPRESENTATION



FRAME REPRESENTATION



FRAME REPRESENTATION



FRAME REPRESENTATION



FRAME REPRESENTATION

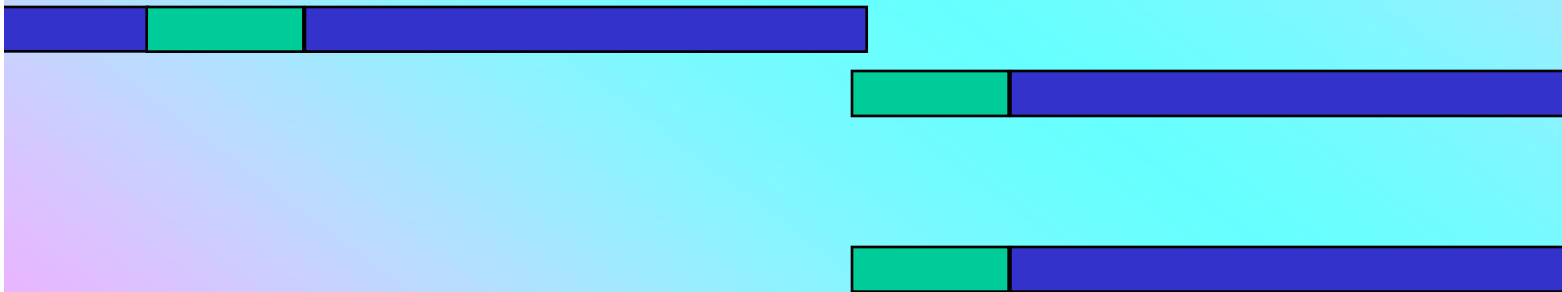

FRAME REPRESENTATION



FRAME REPRESENTATION



FRAME REPRESENTATION



FRAME REPRESENTATION



FRAME REPRESENTATION



FRAME REPRESENTATION



FRAME REPRESENTATION



FRAME REPRESENTATION



FRAME REPRESENTATION



FRAME REPRESENTATION



FRAME REPRESENTATION



FRAME REPRESENTATION



FRAME REPRESENTATION

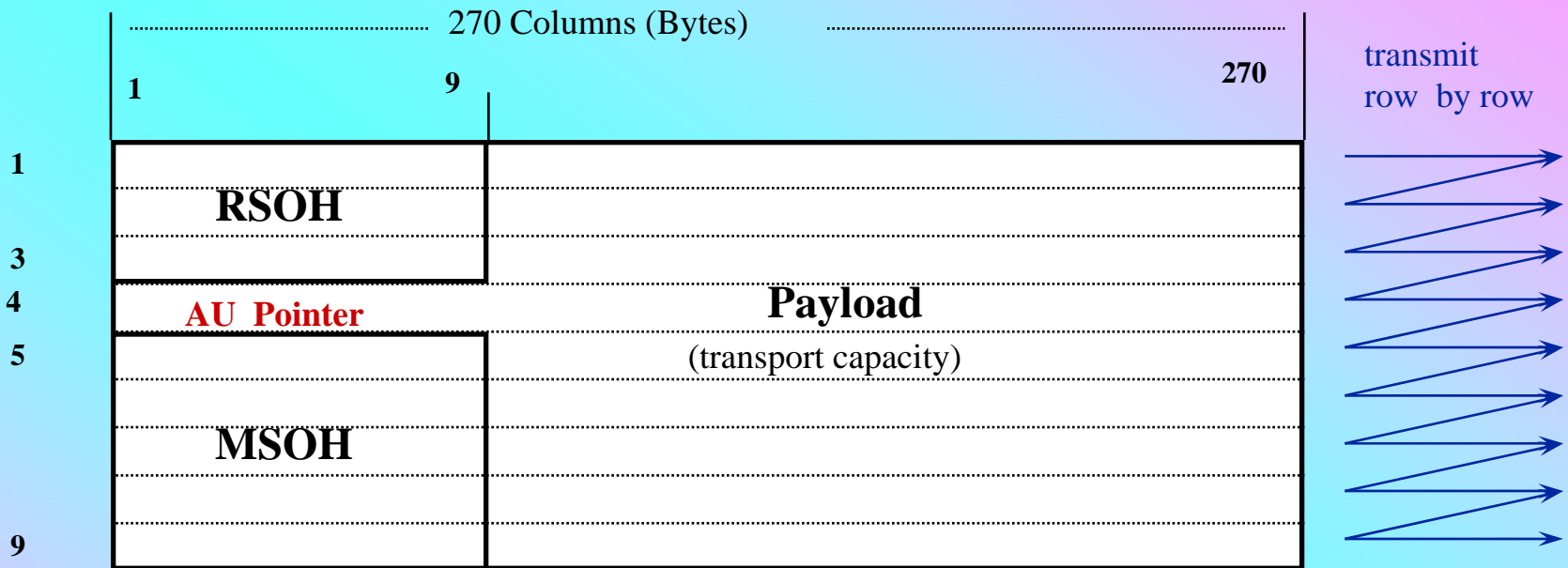

RSOH: Regenerator section overhead
MSOH: Multiplex section overhead
Payload: Area for information transport

Transport capacity of one Byte: 64 kbit/s
Frame capacity: $270 \times 9 \times 8 \times 8000$
 $= 155.520$ Mbit/s
Frame repetition time: 125 μ s

BIT RATE : STM-N ??

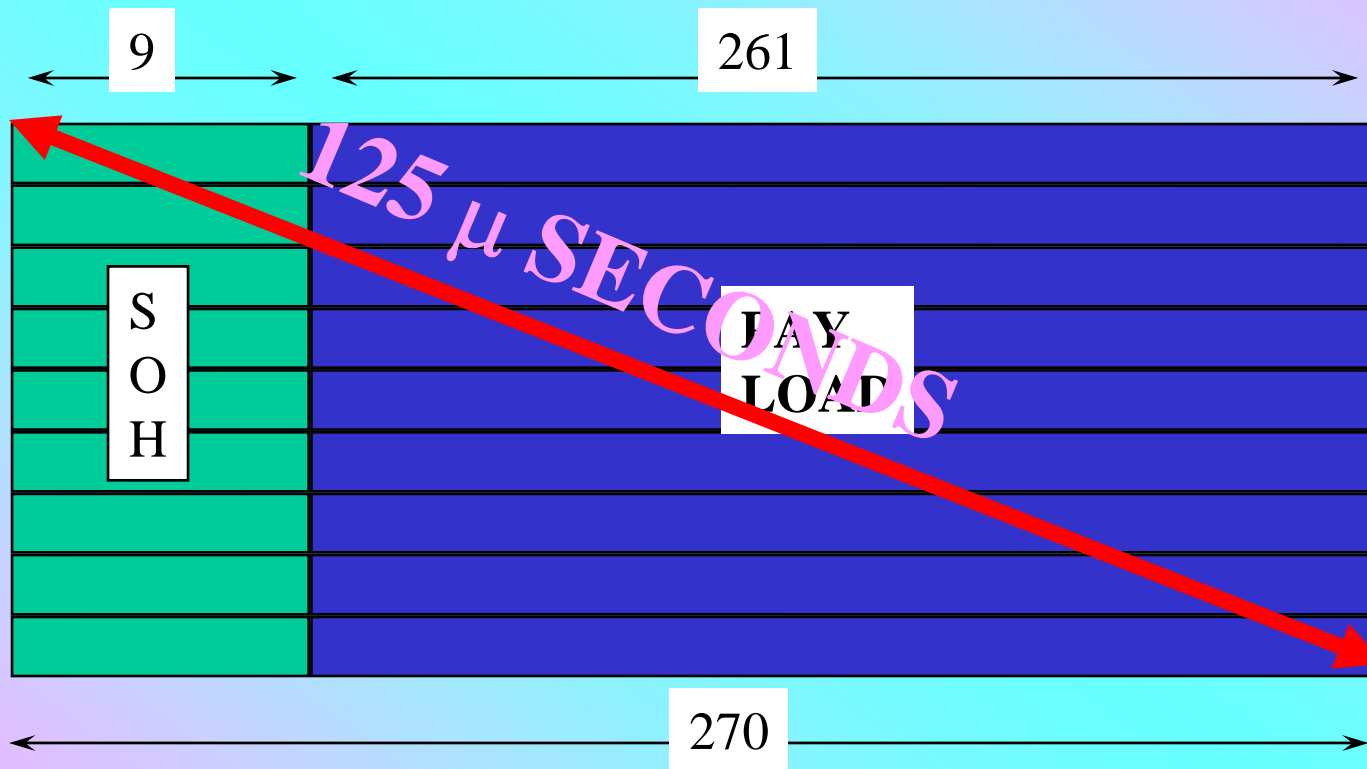

(MATRIX REPRESENTATION)

BIT RATE : STM-N

- **NUMBER OF ROWS = 9**
- **NUMBER OF COLUMNS = 9+261=270**
- **NUMBER OF BYTES = 9x270**
- **NUMBER OF BITS = 9x270x8**
- **NUMBER OF BITS / SECOND = 9x270x8x8000**
=155520000
=155.520 Mbps (STM-1)
- **BIT RATE OF STM-N = (Nx155.520) Mbps**

Pointers

The pointer technology provides a means to accommodate timing differences at SDH networks. The pointer indicates the start of the payload within a STM-1 frame.

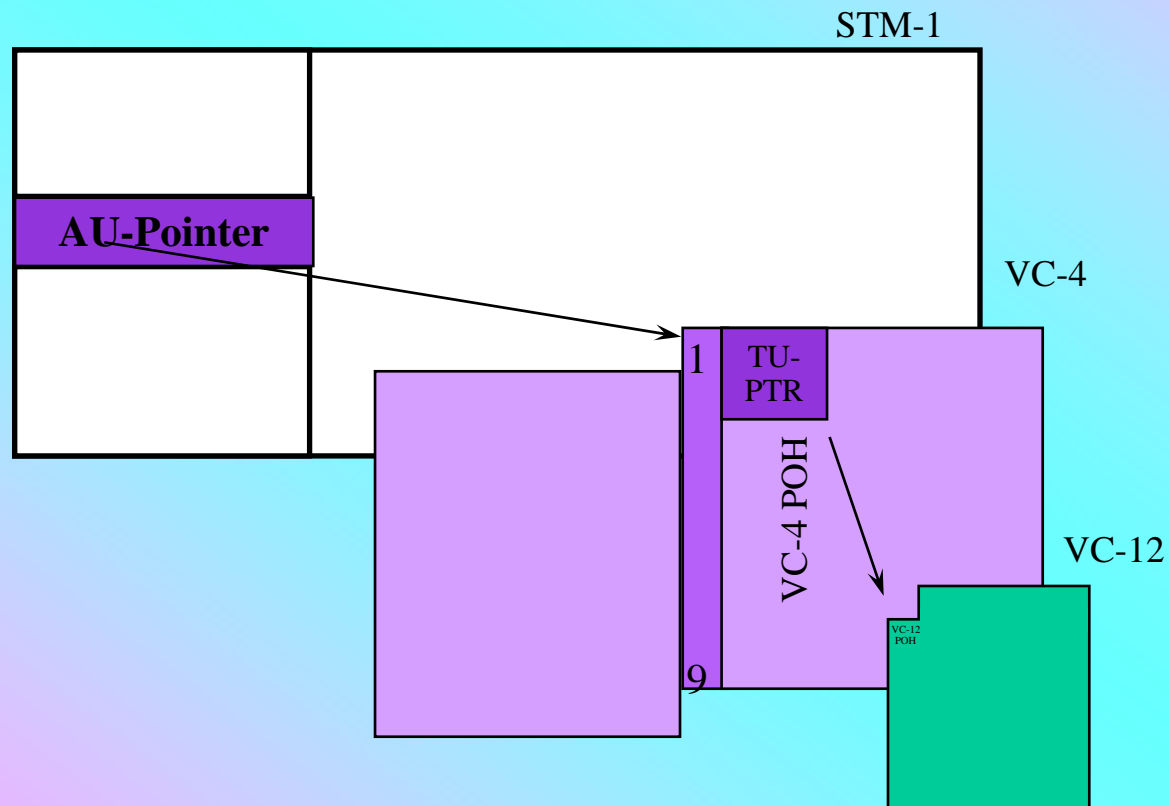

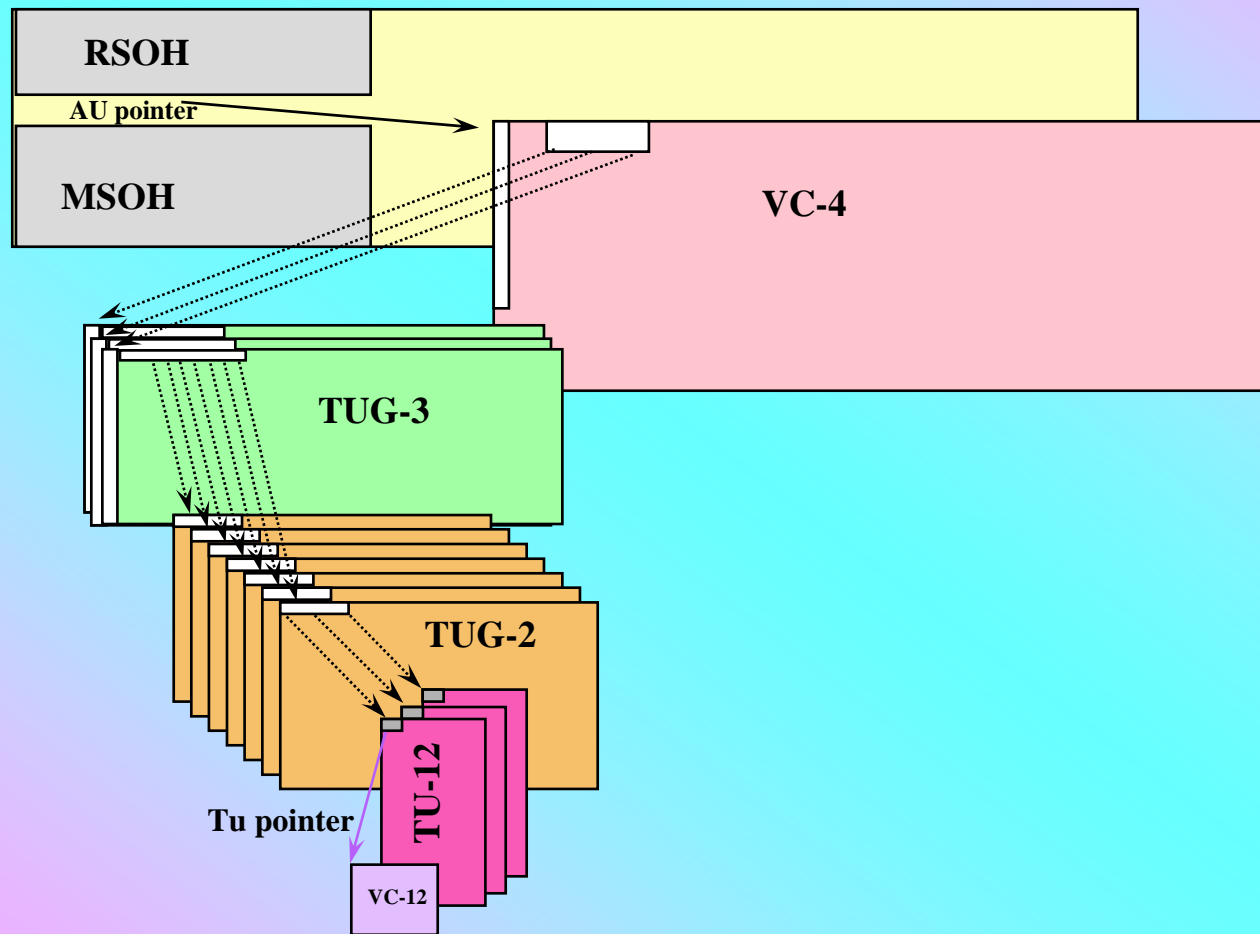

SECTION OVERHEAD DETAILS

A1	A1	A1	A2	A2	A2	J0		
B1	○	○	E1	○		F1		
D1	○	○	D2	○		D3		

B2	B2	B2	K1			K2		
D4			D5			D6		
D7			D8			D9		
D10			D11			D12		
S1					M1	E2		

A FRAMING

D DATACOM FOR NMS

F USER CHANNEL

K APS

RESERVED FOR NATIONAL USE

UNUSED RESERVED FOR FUTURE USE

B PARITY CHECK

E ORDERWIRE

M MS-REI

○ MEDIA DEPEDENT

NETWORK ELEMENTS

SYNCHRONOUS MULTIPLEXER (MUX):

- * MAPPING OF PDH SIGNALS INTO SDH.
- * MULTIPLEXING OF LOWER -ORDER SDH SIGNALS INTO SDH

**63 Nos. OF 2Mbps or
3 Nos.of 34Mbps or
1 Nos. of 140Mbps or
combination of above**

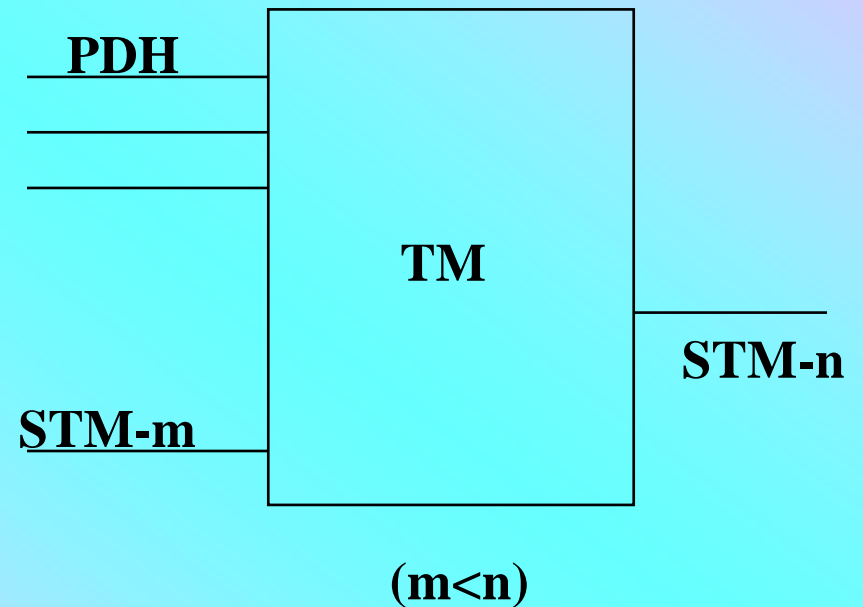

NETWORK ELEMENTS

ADD & DROP MULTIPLEXER (ADM):

* PERMITS ADD& DROP OF LOWER ORDER SIGNALS.

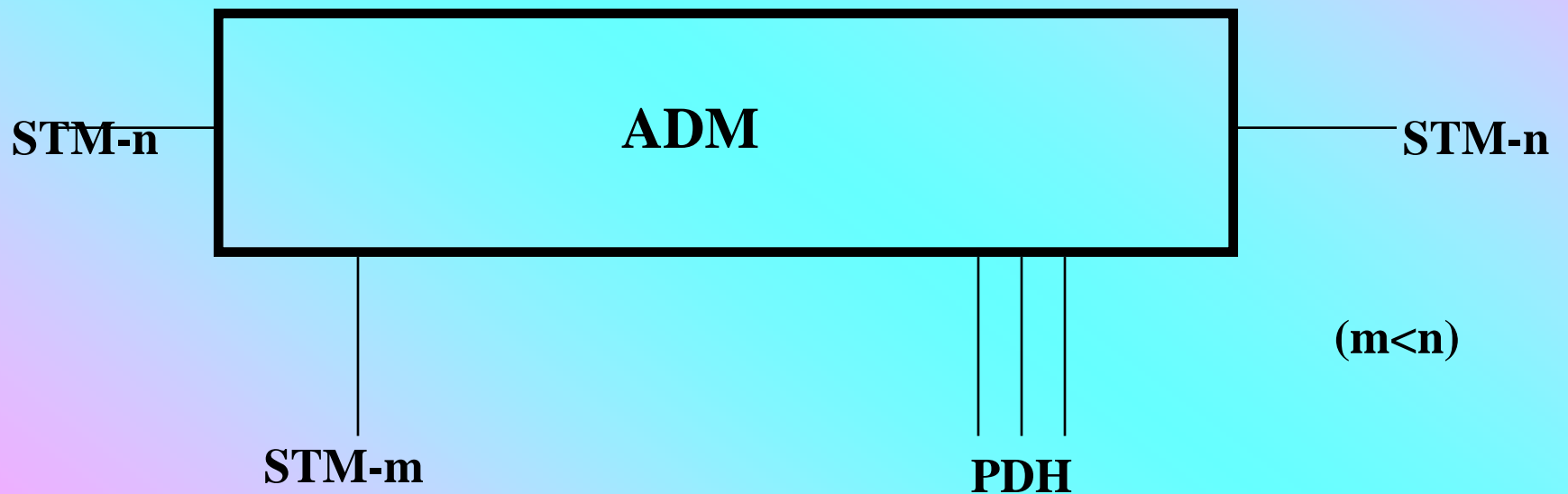

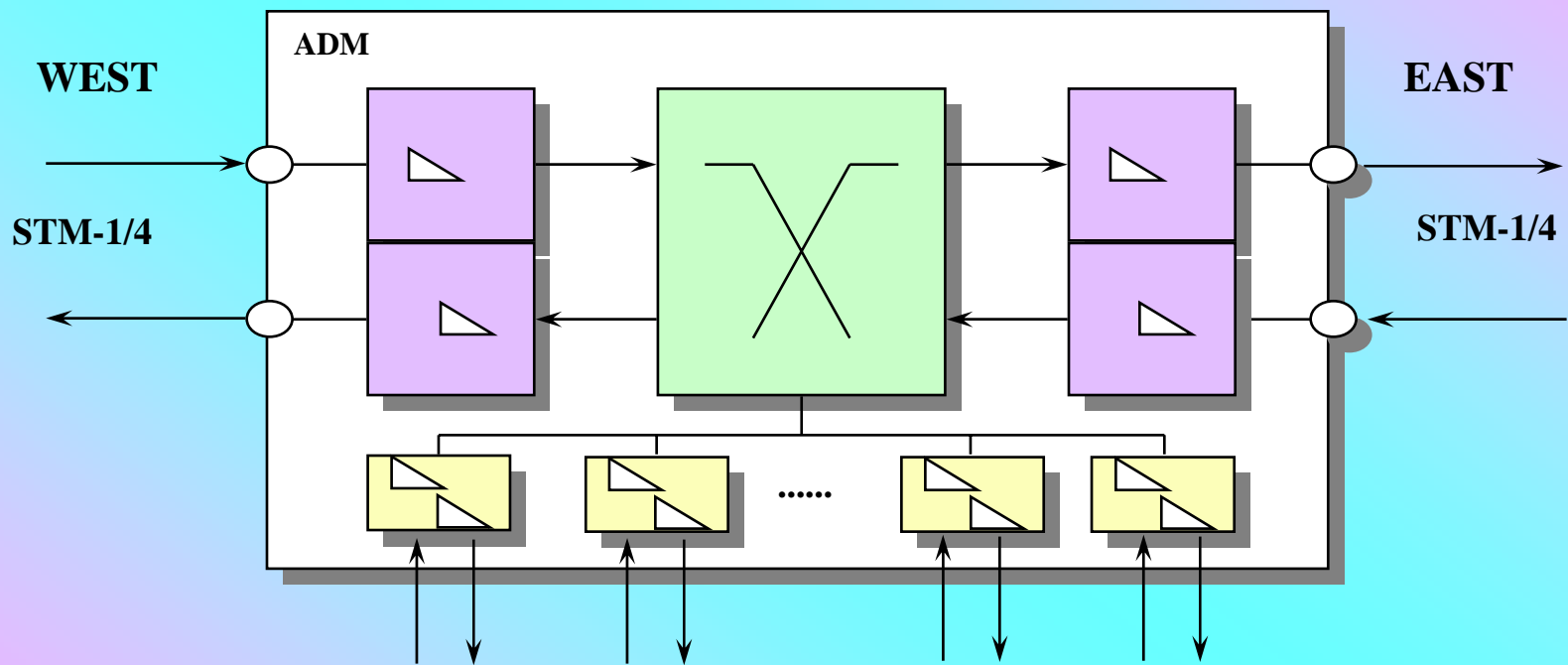

Tributary Ports : $n \times 2$ Mbit/s (34 Mbit/s)

NETWORK ELEMENTS

SYNCHRONOUS DIGITAL CROSS CONNECT (SDXC):

- * PERMITS SWITCHING OF TRANSMISSION LINES WITH DIFFERENT BIT-RATES.
- * SDXC CAN ADD AND DROP LOWER-ORDER SIGNALS.

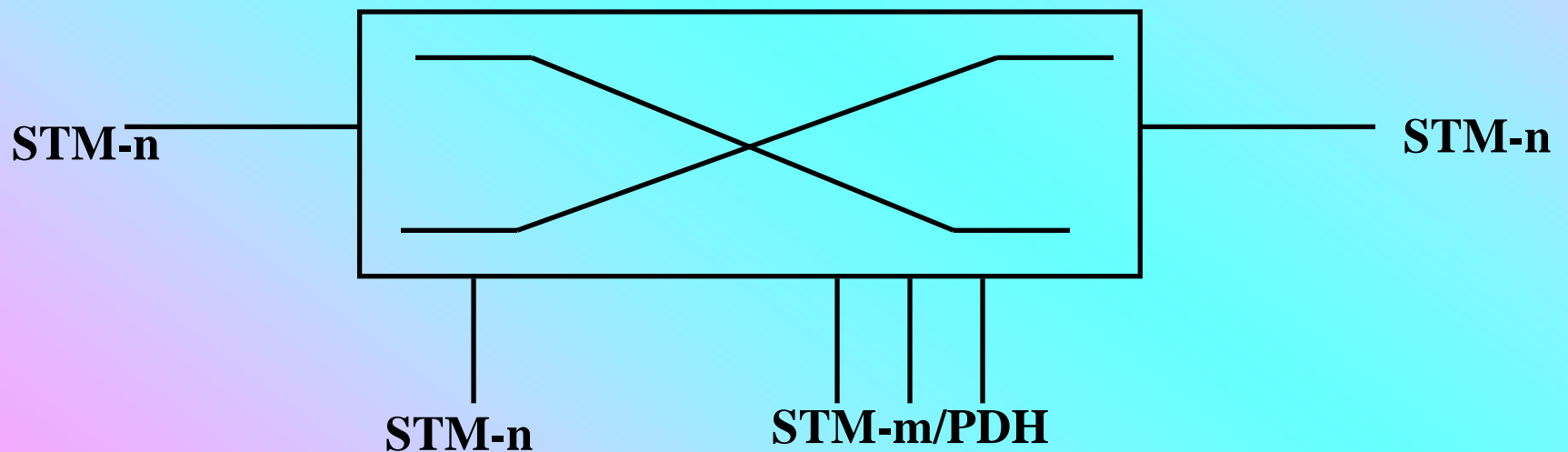

Synchronous Cross Connect

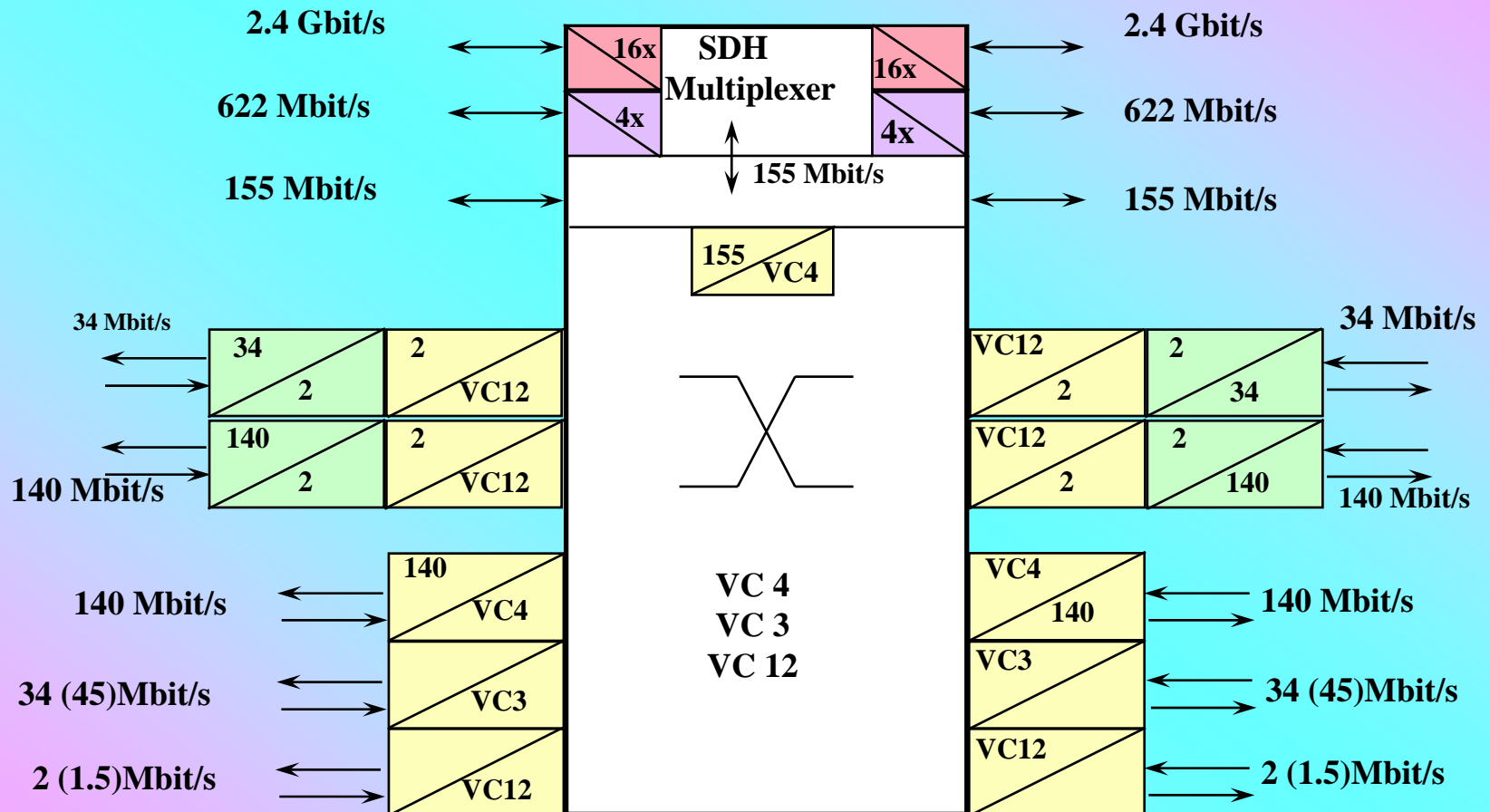

NETWORK ELEMENTS

SYNCHRONOUS REGENERATOR (REG):

- * REGENERATES THE INCOMING LINE SIGNAL.
- * SUPERVISE THE TRANSMISSION QUALITY OF THE LINE



NETWORK ELEMENTS

N M S

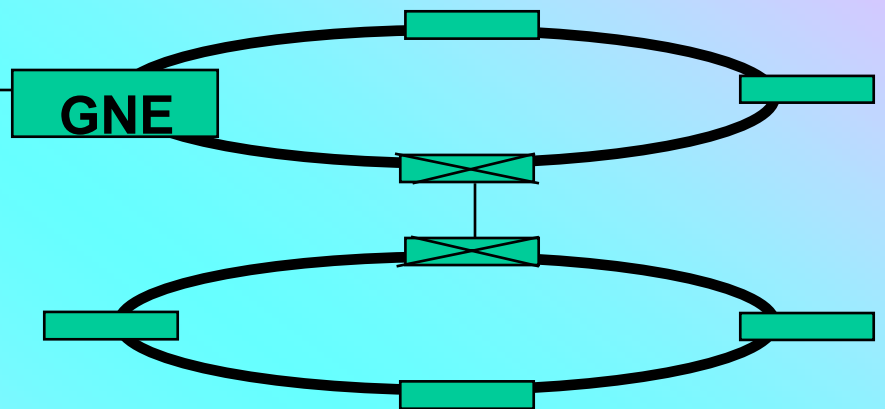

SDH AIMS TO PROVIDE:

STANDARDISED , CENTRALISED O&M SYSTEM .

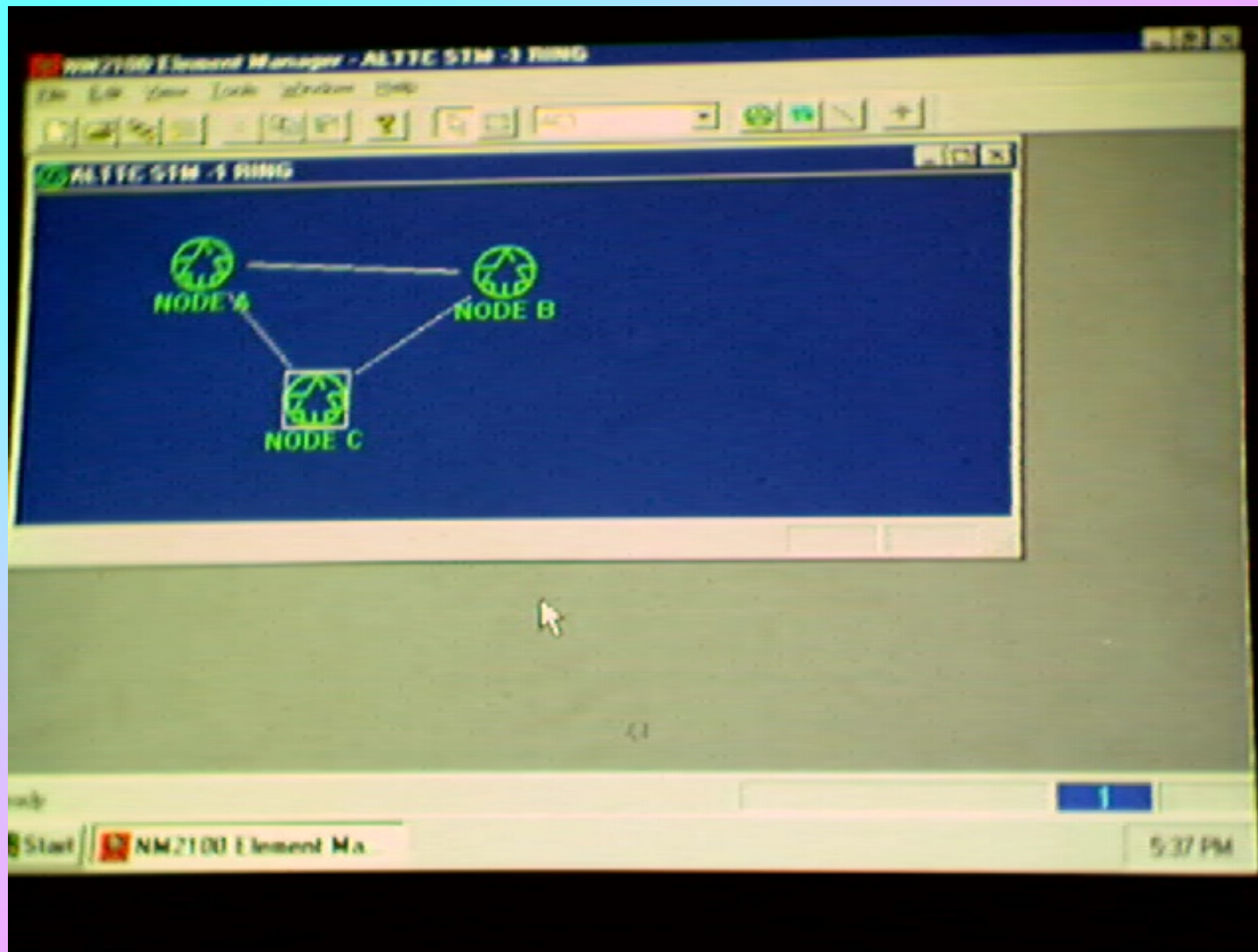

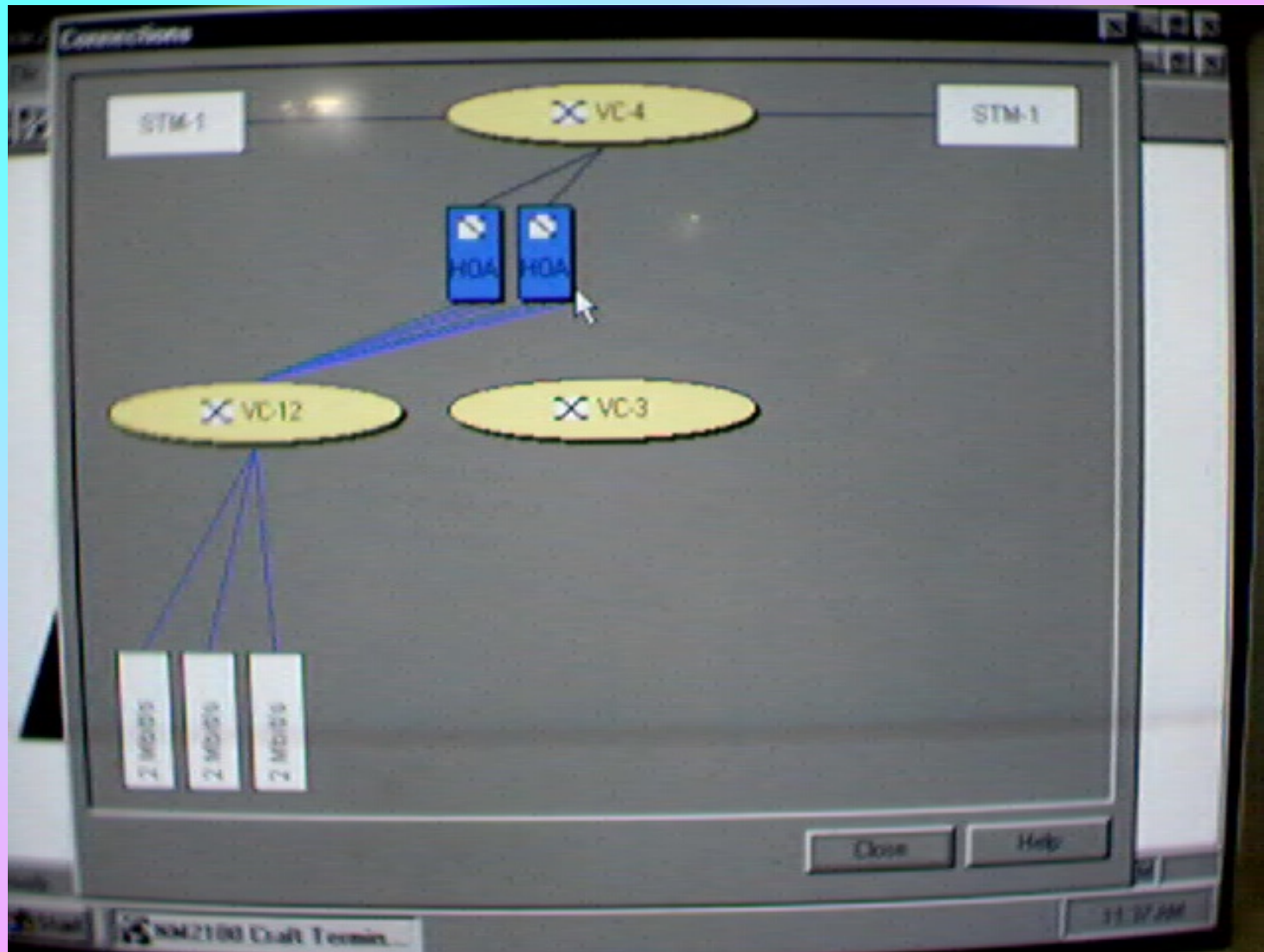

SDH MANAGEMENT

- **Performance Management**
- **Fault / Event Management**
- **Configuration Management**

NETWORK TOPOLOGY

* POINT-TO-POINT:

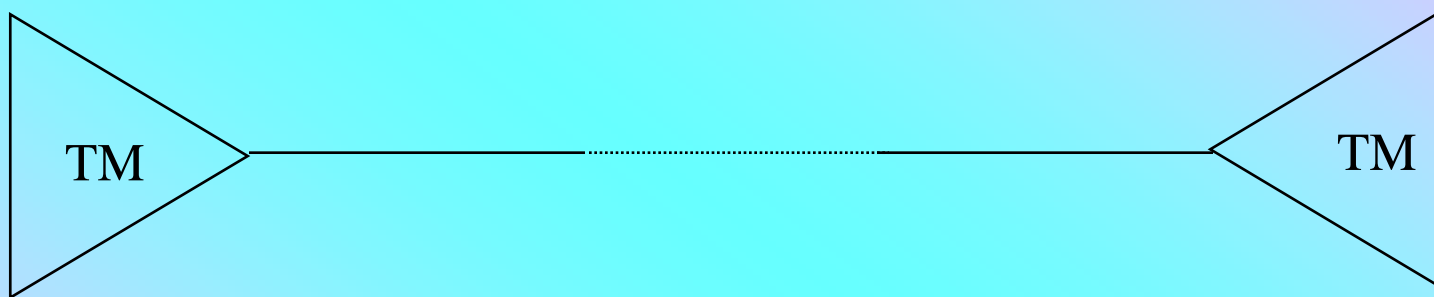

* POINT-TO-MULTIPOINT:



NETWORK TOPOLOGY

* HUB-TOPOLOGY:

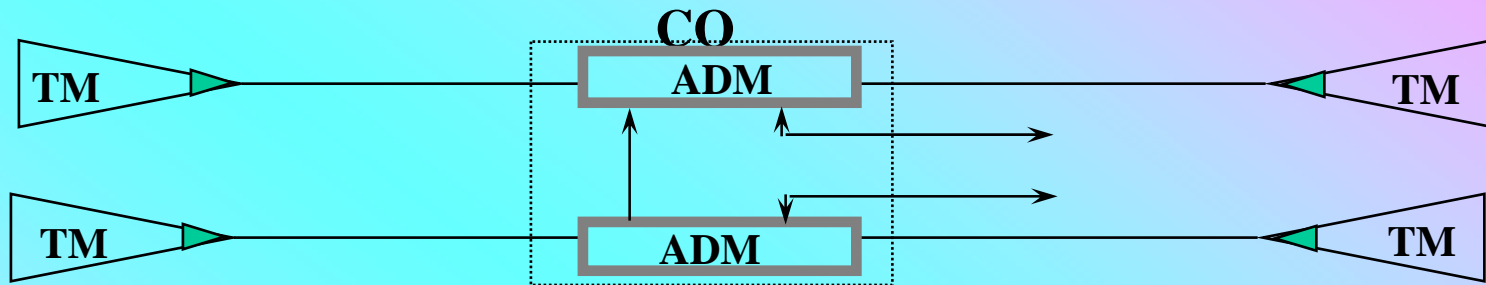

(a) HUB WITH TM & ADM

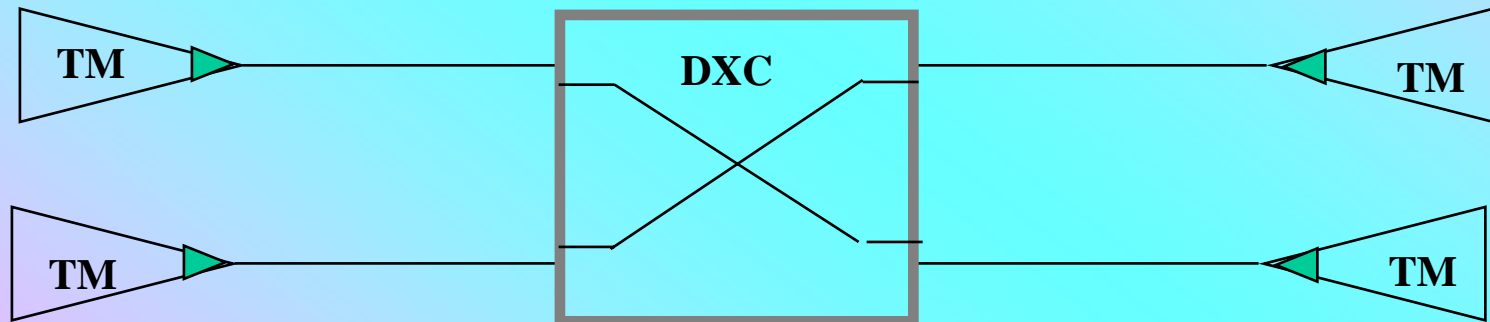

(b) HUB WITH TM & DXC

NETWORK TOPOLOGY

* RING-TOPOLOGY:

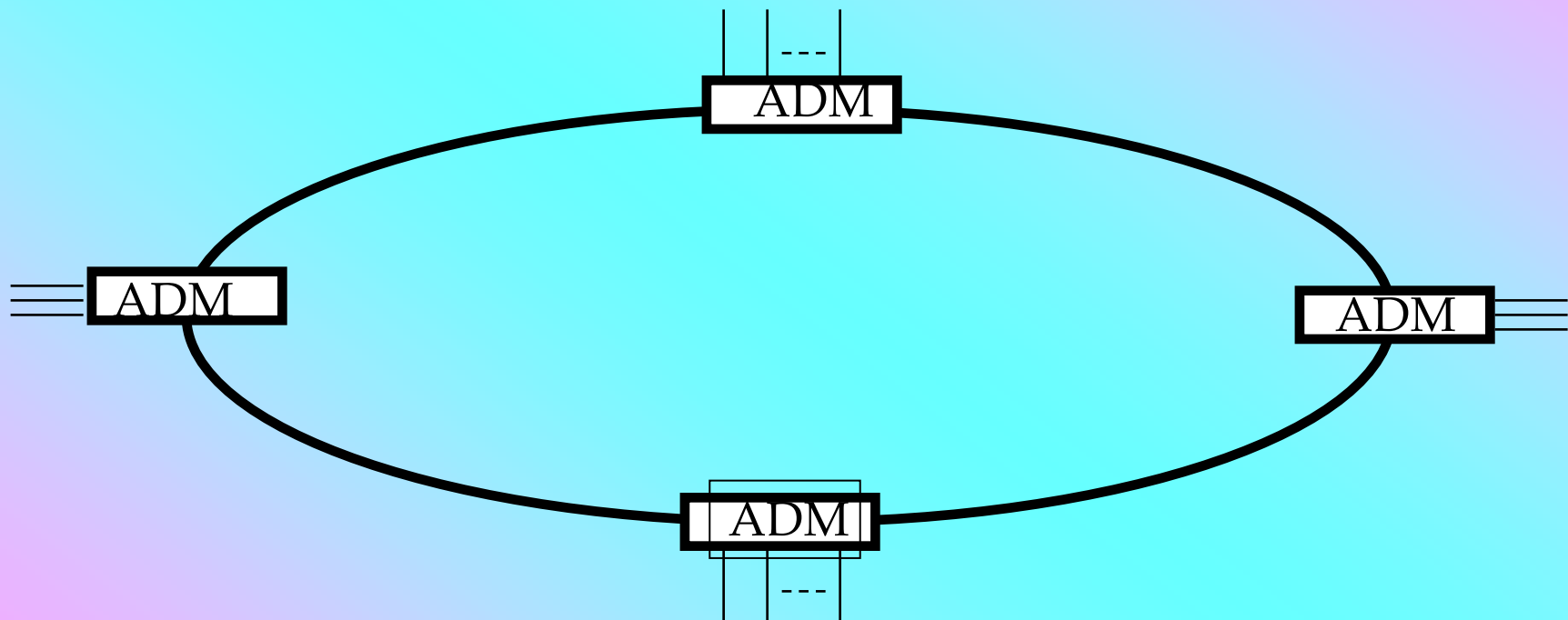

SDH NETWORK STRUCTURE

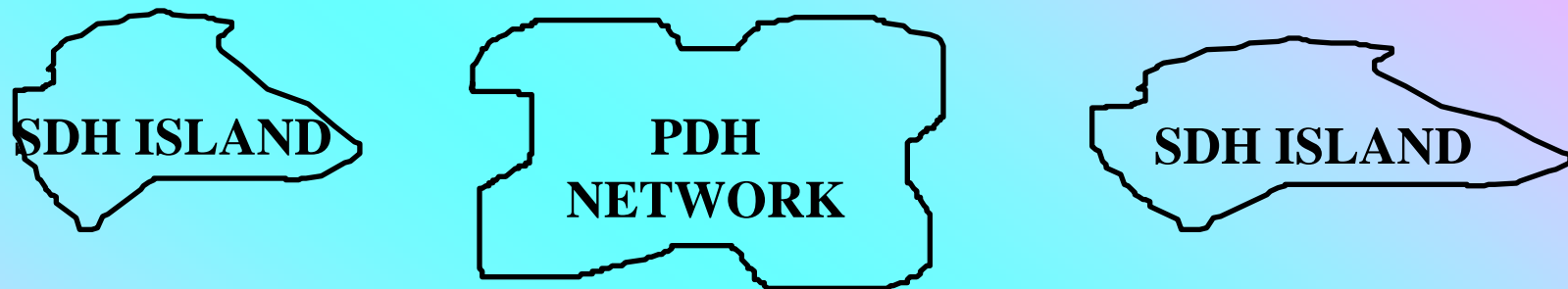

a) Mixed SDH-PDH network

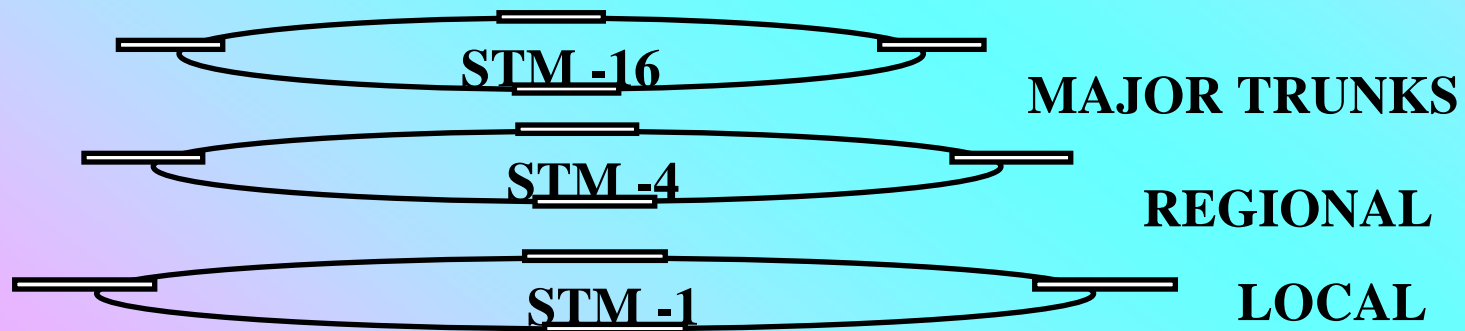

b) Typical use of SDH rates.

SDH NETWORK STRUCTURE

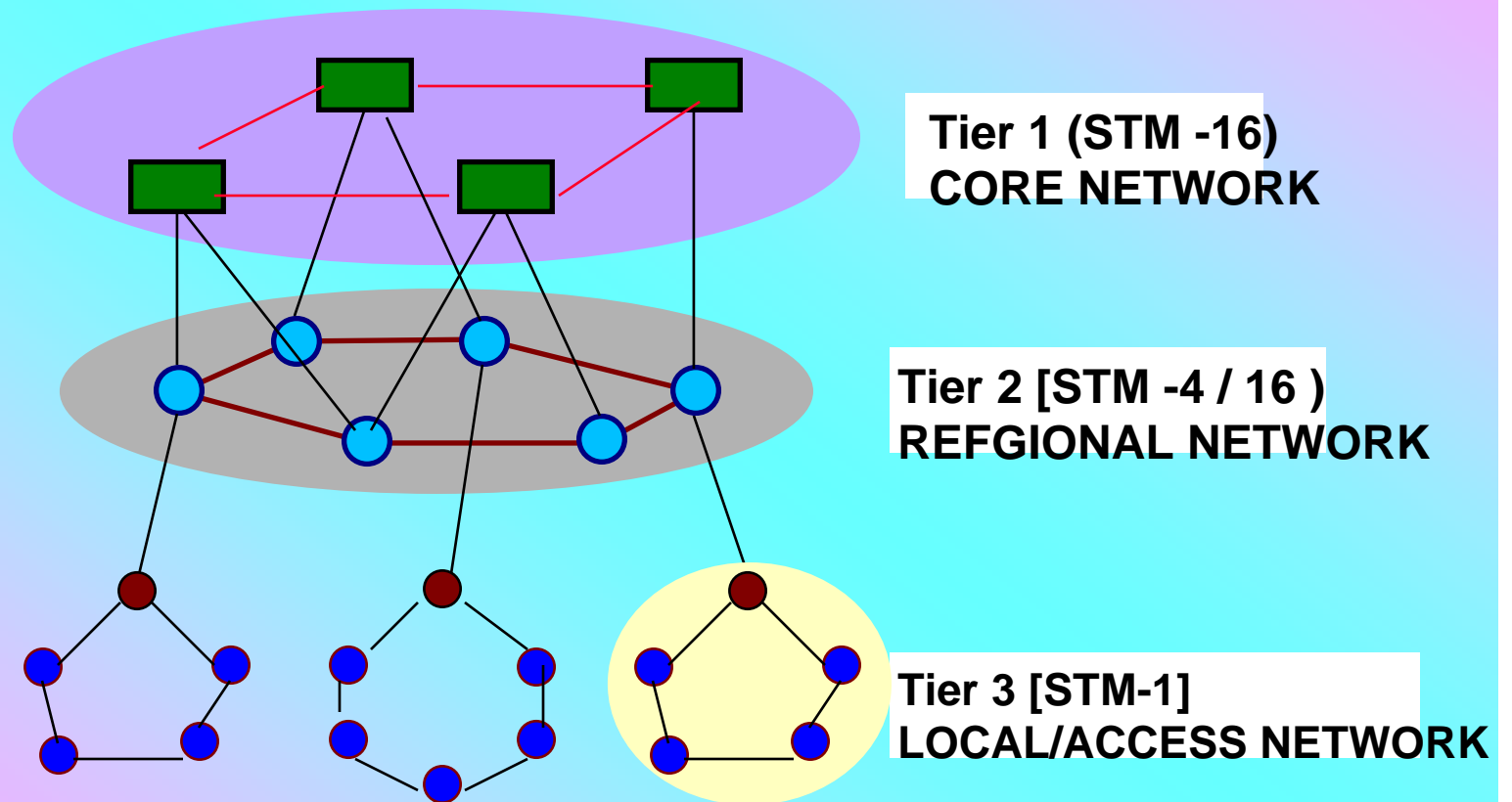

**Trunk
Network L 2**

**Trunk Network
L 1**

SDH Network Topology

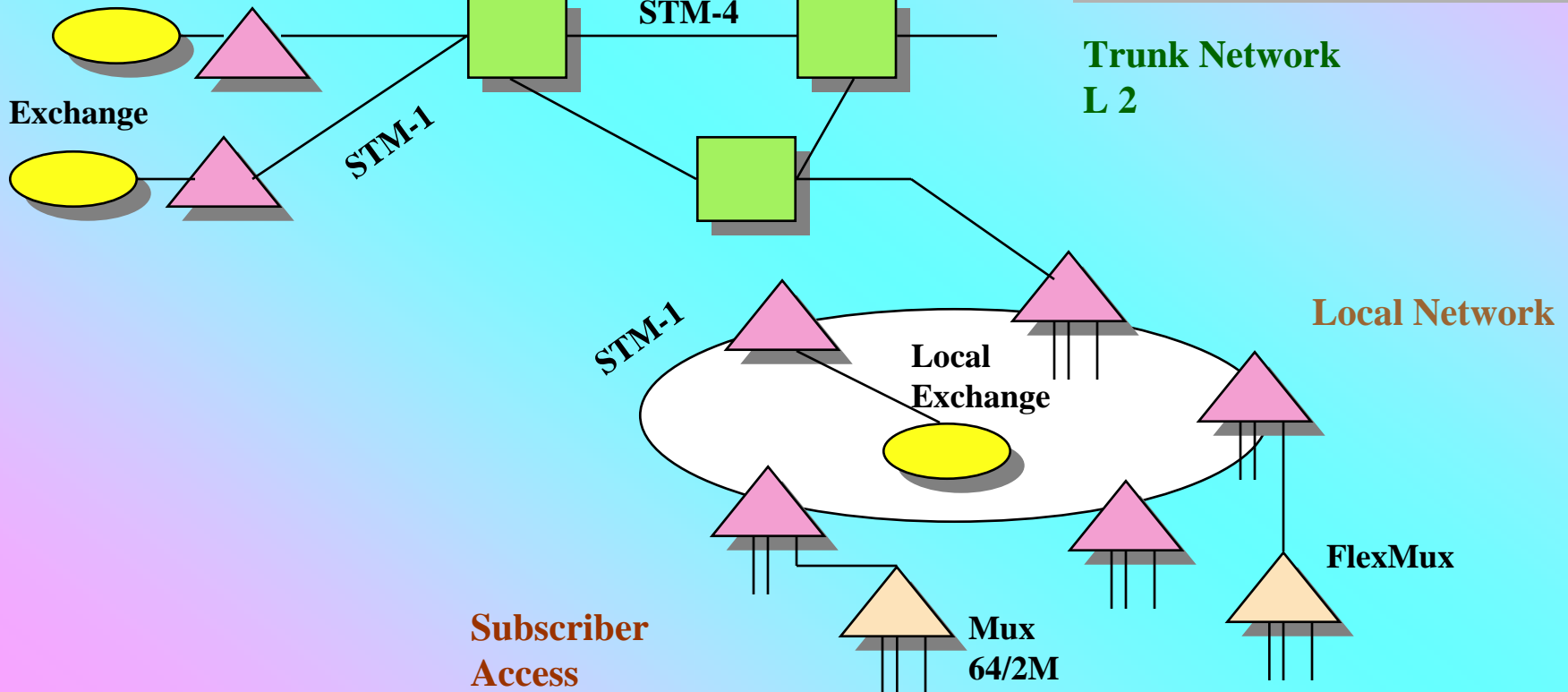

Unidirectional Ring

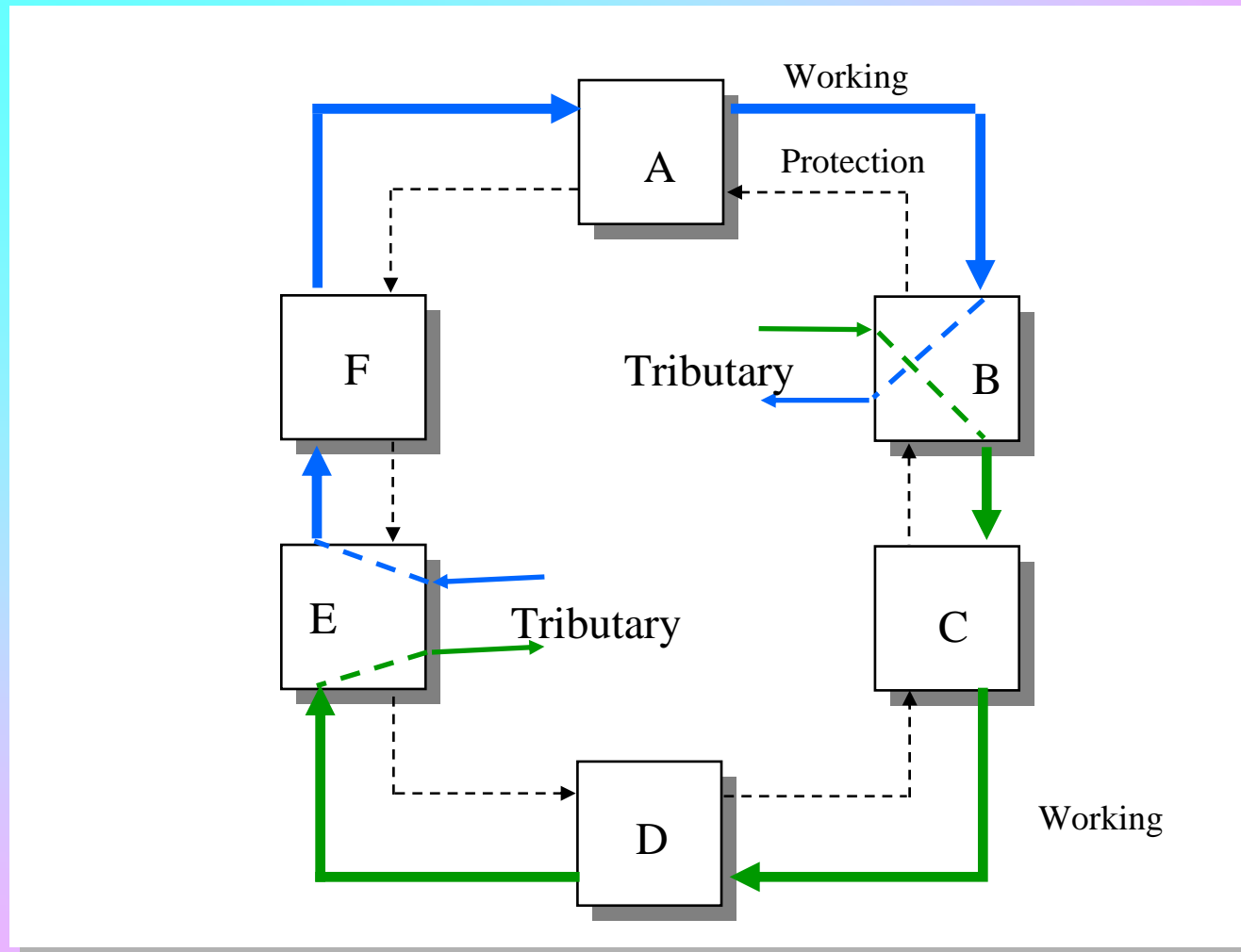

Two fiber Bidirectional Line-Switched Ring (BLSR)

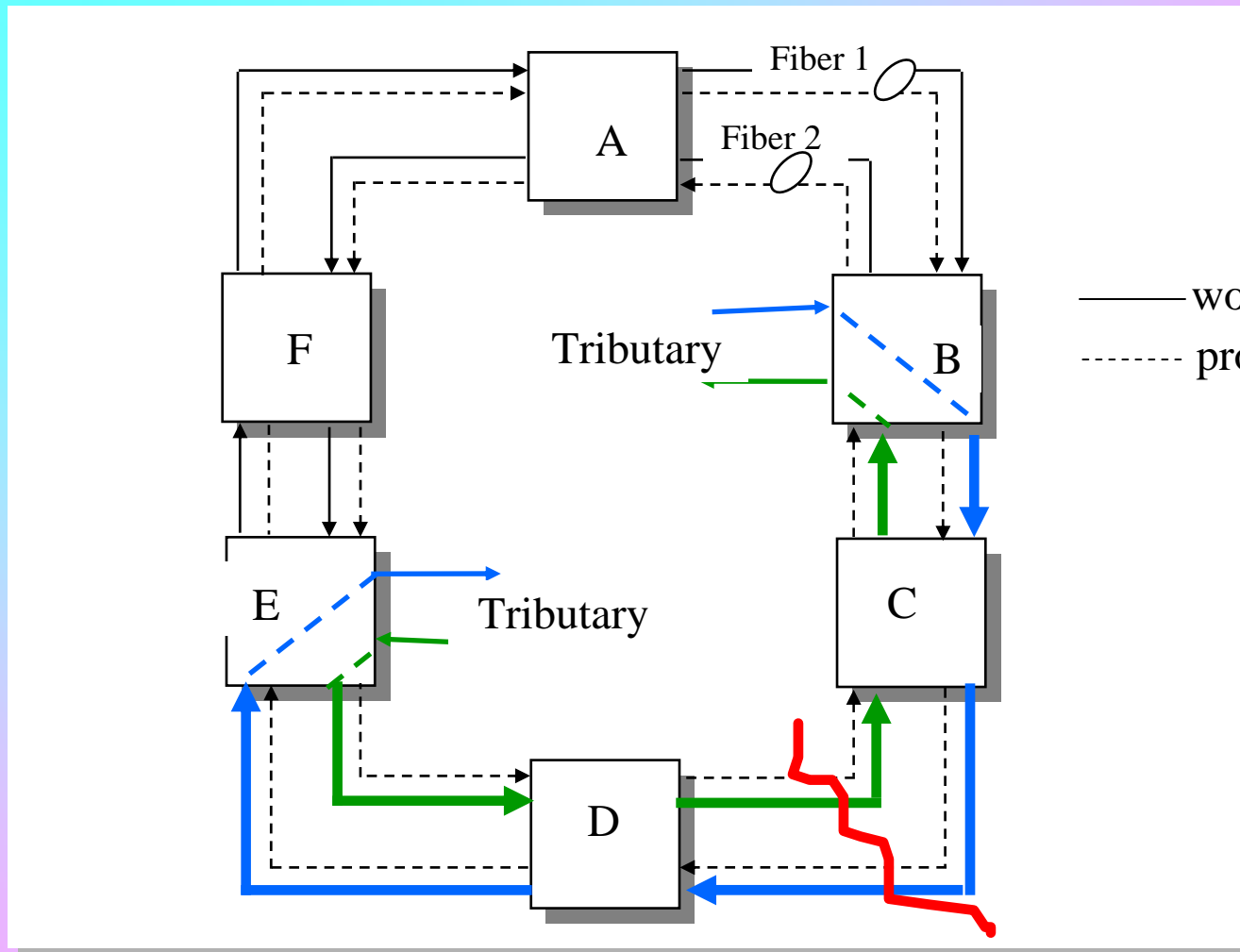

THANK YOU